

NOTES:

- 1 ALL DIMENSIONS SHOWN ARE FINISH OPERATIONAL DIMENSIONS WHICH INCLUDE RESIDUAL COATINGS UNLESS OTHERWISE SPECIFIED.
- 2 PART TO BE PACKED PROPERLY TO AVOID ANY DAMAGE WHILE SHIPPING & HANDLING.
- 3 ALL HORIZONTAL DIMENSIONS ARE SYMMETRICAL ABOUT CENTER LINE UNLESS OTHERWISE SPECIFIED.

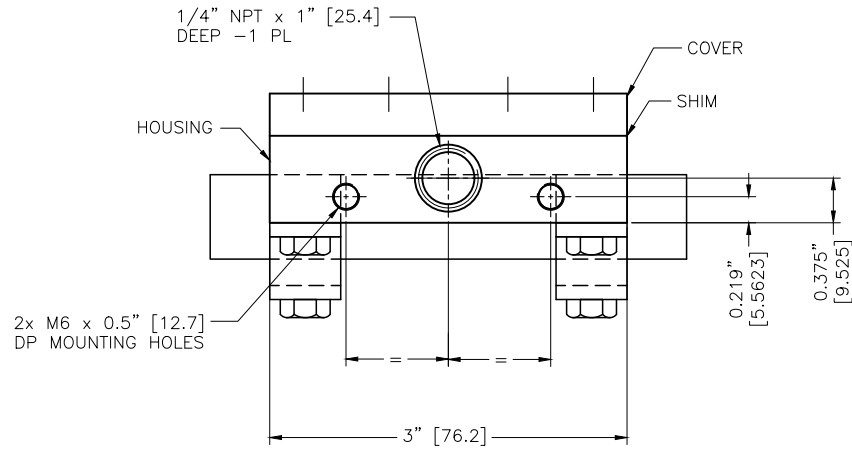
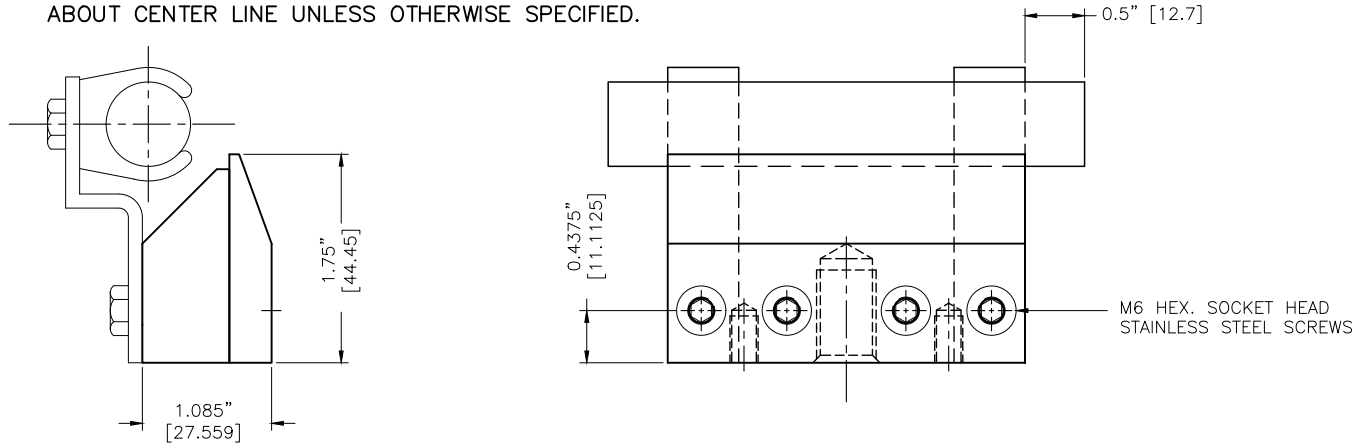

<p>PROPRIETARY REPRODUCTION OR DISTRIBUTION WITHOUT WRITTEN CONSENT OF NEXFLOW™ IS PROHIBITED.</p>						<p>REQUIREMENTS—UNLESS OTHERWISE SPECIFIED</p> <p>GENERAL</p> <ol style="list-style-type: none"> DIMS ARE IN INCHES (MM) DIMENSIONING AND TOLERANCING IN ACCORDANCE WITH ANSI Y14.5 (1982) MACHINE FINISH 125 MICRO INCH RMS INTERNAL RADI .015 BREAK SHARP CORNERS .005 TO .015 <p>LIMITS</p> <ol style="list-style-type: none"> LINEAR DIMS. XXX = .005 XX = .010 X = .030 ANGLES = ± 1/2° RUNOUT .010 TIR HOLES IN ACCORDANCE WITH AND 10387 	<p>CONTRACT NUMBER —</p> <p>CLIENT —</p> <p>CONTRACTOR —</p> <p>DESIGN —</p> <p>PROJECT —</p> <p>STRESS —</p> <p>THERMAL —</p> <p>MECHANISM —</p>	<p>DATE 10/04/2021</p> <p>CHECKED LES</p> <p>DRAWN CHRAGS</p> <p>MANUFACTURING —</p> <p>MATERIALS —</p> <p>ELECTRICAL —</p>	<p>NEX FLOW AIR PRODUCTS CORP. 10520 YONGE STREET, UNIT 35B-220, RICHMOND HILL, ON L4C 3C7 TEL.: (416) 410-1313 & FAX: (416) 410-1806 www.nex-flow.com</p> <p>TITLE OUTLINE DRAWING OF 3" X-STREAM AIR BLADE AIR KNIFE WITH RN IONIZER / VS IONIZER</p> <p>SIZE —</p> <p>CAGE CODE —</p> <p>DWG NO 15003X - 16003X</p> <p>SCALE 1:1</p>	<p>RELEASE —</p> <p>REV —</p> <p>SHEET 1 OF 1</p>
	MATERIAL	ALUMINIUM								
	FINISH	—								
			NEXT ASSEMBLY	USED ON	QTY PER ASST	PART NO				