

STANDARD AIR BLADE® AIR KNIFE

Blowoff, clean, cool and dry with a strong curtain of amplified airflow

WHAT ARE THEY - REASONS TO USE

Standard Air Blade® Air Knife Blowoff System from Nex Flow® is easy to mount and maintain, reducing both compressed air consumption and noise levels.

The Standard Air Blade® Air Knife Blowoff System produces a "Laminar" flow of air along its length using the "Coanda" effect which "entrains" a large volume of air from the surrounding area along with the small amount of compressed air from the Air Blade® Air knife to produce an output flow up to 30 times System payback on compressed air savings can be as soon as a few weeks in some applications. It is less costly than the highly efficient and quiet Silent Air Blade® Air Knife but it is popular for more heavy duty installations due to its greater bulk. In addition, it is excellent for some applications when mounted flush to a flat surface to create an extended air barrier along that surface. Normally the X-Stream® version is most efficient although the Standard would be lowest initial.cost.



A Model 10018 Standard Air Blade® Air Knife is used to blow scrap pieces and dirt from cellular phone parts after machining.

STANDARD AIR BLADE® AIR KNIFE FEATURES:

- ▶ No moving parts - anodized aluminum or stainless steel
- ▶ Compact design, simple, lightweight and portable
- ▶ Rugged design
- ▶ Full flow - air across entire length of Air Knife
- ▶ Air inlets at ends and back
- ▶ Driven by air not electricity
- ▶ Replaces drilled pipe and open jets or nozzles used for blowoff, cleaning, drying and cooling
- ▶ High airflow amplification
- ▶ Instant on-off, no electricity or explosion hazard

STANDARD AIR BLADE® AIR KNIFE BENEFITS:

- ▶ Longer life in difficult environments than competitive models
- ▶ Lower compressed air consumption than drilled pipe or rows of open jets and nozzles.
- ▶ Can be placed end to end for continuous airflow.
- ▶ Maintenance free with output easily controlled, safe to use.



Mounting and holding systems are available for the Standard Air Blade Air Knife. Fully flexible positioning
See Accessories

NOTE: Plastic shims can wear out quickly in Air Knives if the air is not clean. Nex Flow® uses only stainless steel shims.

STANDARD AIR BLADE® AIR KNIFE - HOW IT WORKS:

Standard Air Blade® Air Knife - Compressed air enters the Air Knife at the rear (or end) ports at (A). Air is entrained at point (B) by the compressed air stream that leaves the Air Knife from a small gap. The entrained air follows the "Coanda" profile along the front face (C) that directs the air flow in a perfect straight line at 90 degrees to create a uniform sheet of air along the entire length of the Air Blade® Air Knife. As the air leaves the Air Knife at point (D) the amplified air stream maximizes velocity and force is maximized as a well-defined sheet of laminar flow with minimal wind shear for reduced energy use in blowoff and cooling.

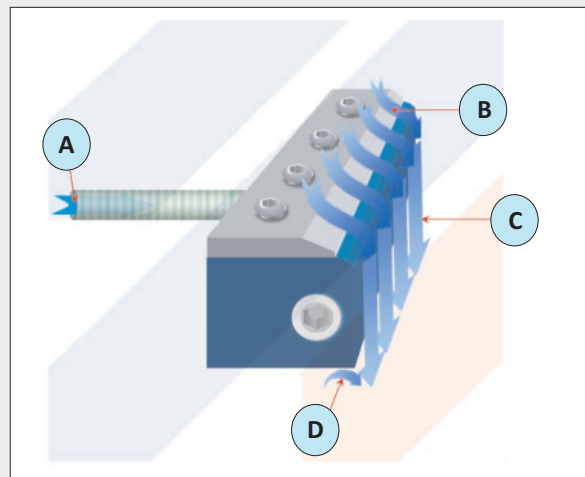

Standard Air Blade® Air Knife is available in eight standard lengths in anodized aluminum and in seven lengths in stainless steel: 3" (76 mm), 6" (150 mm), 8" (203.2 mm) (not available in stainless), 12" (300 mm), 18" (457 mm), 24" (609.5 mm), 30" (761 mm), 36" (914 mm)

Sound Level 78 dBA at 80 PSIG (5.5 BAR) for Standard Air Blade® Air Knives

PART NO. (Aluminum & Stainless Steel)	AA Inches (mm)	A Inches (mm)	B Inches (mm)	C Inches (mm)	D Inches (mm)	E Inches (mm)	F Inches (mm)	G Inches (mm)	H Inches (mm)	Number of Rear Inlet (Side Inlets)
Model 10003 Aluminum	3"(76.2)	.625"(15.9)	N/A	N/A	2.375"(60.3)	0.344"(8.7)	1.50"(38.1)	N/A	N/A	1(2)
Model 10003S Stainless	3"(76.2)	.625"(15.9)	N/A	N/A	2.375"(60.3)	0.344"(8.7)	1.50"(38.1)	N/A	N/A	1(2)
Model 10006 Aluminum	6"(152)	1"(25.4)	N/A	N/A	5.0"(12.7)	0.344"(8.7)	3.0"(76.2)	N/A	N/A	1(2)
Model 10006S Stainless	6"(152)	1"(25.4)	N/A	N/A	5.0"(12.7)	0.344"(8.7)	3.0"(76.2)	N/A	N/A	1(2)
Model 10008 Aluminum	8"(203.2)	1.187"(30)	2.37"(60.2)	5.63"(143)	6.813"(162)	0.344"(8.7)	4.0"(101.6)	N/A	N/A	1(2)
Model 10008S Stainless	8"(203.2)	1.187"(30)	2.37"(60.2)	5.63"(143)	6.813"(162)	0.344"(8.7)	4.0"(101.6)	N/A	N/A	1(2)
Model 10012 Aluminum	12"(305)	1"(25.4)	3.1"(78.7)	8.9"(127)	11.0"(279)	0.344"(8.7)	6.0"(152)	N/S	N/S	1(2)
Model 10012S Stainless	12"(305)	1"(25.4)	3.1"(78.7)	8.9"(127)	11.0"(279)	0.344"(8.7)	6.0"(152)	N/A	N/A	1(2)
Model 10018 Aluminum	18"(457)	1.3"(33.4)	5.8"(148)	12.2"(310)	16.7"(424)	0.344"(8.7)	4.25"(108)	13.75"(349)	N/A	2(2)
Model 10018S Stainless	18"(457)	1.3"(33.4)	5.8"(148)	12.2"(310)	16.7"(424)	0.344"(8.7)	4.25"(108)	13.75"(349)	N/A	2(2)
Model 10024 Aluminum	24"(610)	1.3"(33.4)	4.2"(107)	19.8"(503)	22.7"(577)	0.344"(8.7)	7.3"(183)	16.7"(424)	12.0"(304.8)	2(2)
Model 10024S Stainless	24"(610)	1.3"(33.4)	4.2"(107)	19.8"(503)	22.7"(577)	0.344"(8.7)	7.3"(183)	16.7"(424)	12.0"(304.8)	2(2)
Model 10030 Aluminum	30"(761)	1.13"(28.7)	10.92"(277)	19.08"(485)	28.87"(733)	0.344"(8.7)	7.66"(195)	22.34"(567)	N/A	2(2)
Model 10030S Stainless	30"(761)	1.13"(28.7)	10.92"(277)	19.08"(485)	28.87"(733)	0.344"(8.7)	7.66"(195)	22.34"(567)	N/A	2(2)
Model 10036 Aluminum	36"(914)	1.09"(27.7)	10.75"(273)	18.75"(28.4)	34.92"(887)	0.344"(8.7)	7.53"(191)	28.47"(723)	18.8"(478)	2(2)
Model 10036S Stainless	36"(914)	1.09"(27.7)	10.75"(273)	18.75"(28.4)	34.92"(997)	0.344"(8.7)	7.53"(191)	28.47"(723)	18.8"(478)	2(2)

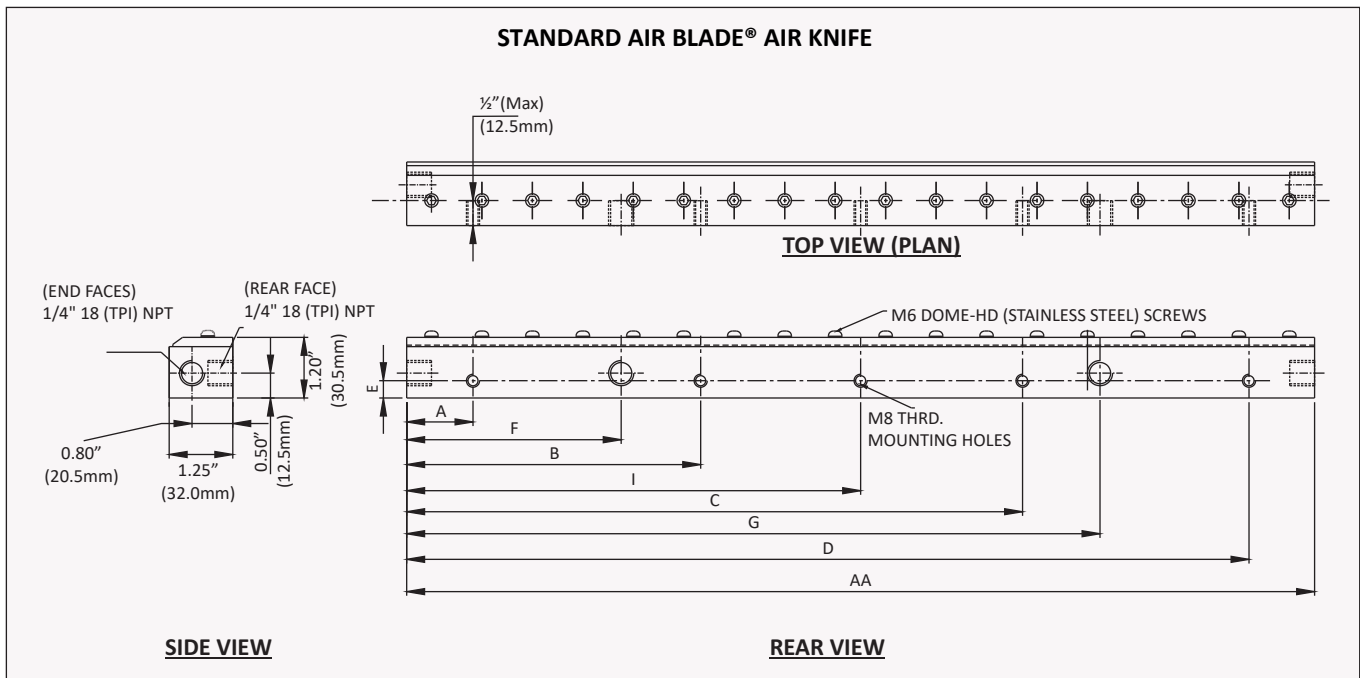

(* BSP Threads or Adaptors can be supplied depending on country location)

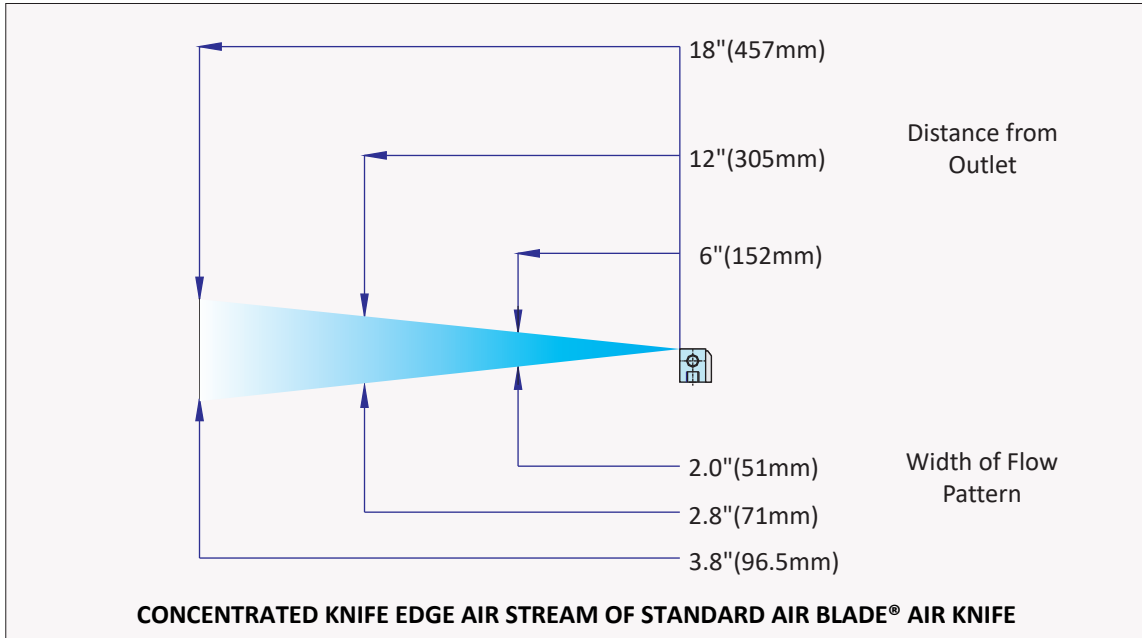

NOTE:

The performance of the X-Stream® Air Blade® Air Knife and the Standard Air Blade® Air Knife will be relatively the same given "same internal chamber conditions. However, due to design the X-Stream® Air Blade® will use about 15% "LESS" compressed air. This generally means less air line pressure drop and "higher" chamber pressures in an X-Stream® Air Blade® given the same application and therefore superior performance (as well as lower noise levels). The Standard Air Blade® Air Knife however is lower cost has applications suited to its unique design.

A Model 10003 3" Standard Air Blade® Air Knife is mounted such that the surface of the Air Knife is flush with the surface of a camera lens. The air flows along the surface of the Air Knife and continues along the lens due to a boundary layer effect that provides a laminar "barrier" to the dirty environmental air, keeping the lens clean and dry.

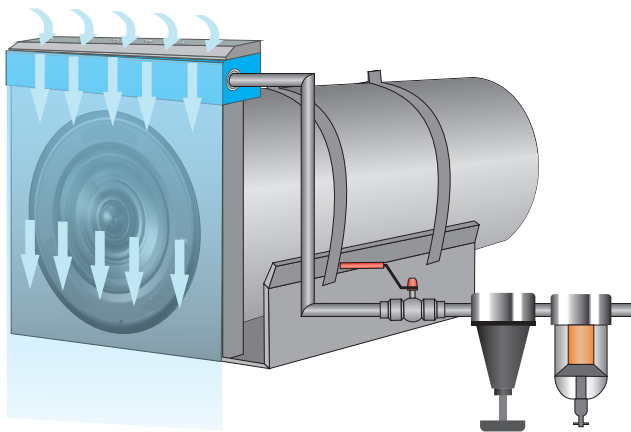

Two Model 10012 Standard Air Blade® Air Knives are installed on a duct (One on top, One on bottom) to draw in waste fumes & exhaust. The air leaving the Air Knives hug the inside wall creating an excellent vacuum inside the duct.

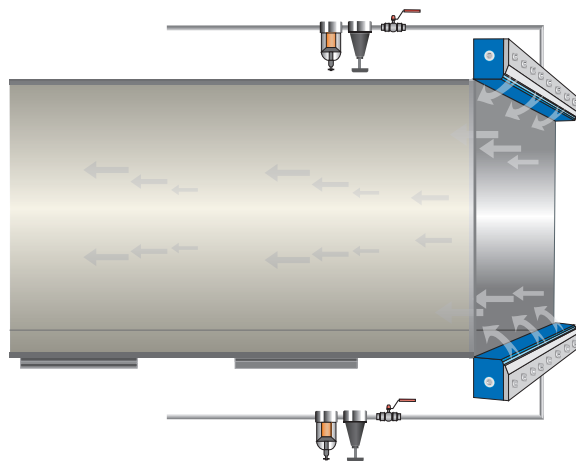

PERFORMANCE CHARTS

10003 / 10003S – 3" Standard Air Blade® Air Knife												
Inlet Pressure (PSIG)	10	20	30	40	50	60	70	80	90	100	110	120
Force (lbs)*	0.005	0.04	0.1	0.18	0.28	0.4	0.53	0.69	0.86	1.06	1.26	1.51
Air Consumption (SCFM)	0.6	1.7	3.7	6	9.1	12	16	20	24	29	34	39
Velocity (ft/s)*	26	40.6	54.7	68.4	80.9	93.5	105	117	128	139	149	158
Inlet Pressure (BAR)	0.7	1.4	2.1	2.8	3.5	4.2	4.9	5.6	6.2	6.9	7.7	8.4
Force (grams)*	2.18	19.6	45.7	83	126	181	242	314	392	481	573	684
Air Consumption (SLPM)	16.6	47.9	105	171	258	350	442	571	681	810	957	1104
Velocity (m/s)*	7.9	12.4	16.7	20.8	24.7	28.5	32.1	35.8	39.1	42.2	45.3	48.1

10006 / 10006S – 6" Standard Air Blade® Air Knife												
Inlet Pressure (PSIG)	10	20	30	40	50	60	70	80	90	100	110	120
Force (lbs)*	0.01	0.05	0.13	0.24	0.35	0.49	0.65	0.83	1.02	1.23	1.46	1.72
Air Consumption (SCFM)	1.6	3.6	6.1	9.1	12	16	20	24	29	34	40	46
Velocity (ft/s)*	5.1	14.1	22.6	30.6	38.1	45.1	52	58	63	68	72	76
Inlet Pressure (BAR)	0.7	1.4	2.1	2.8	3.5	4.2	4.9	5.6	6.2	6.9	7.7	8.4
Force (grams)*	4.35	23.9	61	107	159	222	294	374	462	560	664	779
Air Consumption (SLPM)	44.2	103.1	173	258	350	442	552	681	828	976	1123	1288
Velocity (m/s)*	1.5	4.3	6.9	9.3	11.6	13.7	15.7	17.5	19.1	20.7	22.1	23.3

10008 / 10008S – 8" Standard Air Blade® Air Knife												
Inlet Pressure (PSIG)	10	20	30	40	50	60	70	80	90	100	110	120
Force (lbs)*	0.01	0.06	0.16	0.27	0.4	0.55	0.72	0.92	1.12	1.35	1.6	1.87
Air Consumption (SCFM)	2.5	4.9	7.8	11	14	18	23	27	33	38	44	50
Velocity (ft/s)*	4.7	12.3	19.5	26.1	32.2	37.8	42.9	47.4	51.5	55.1	58.1	60.4
Inlet Pressure (BAR)	0.7	1.4	2.1	2.8	3.5	4.2	4.9	5.6	6.2	6.9	7.7	8.4
Force (grams)*	4.35	28.3	71.8	122	183	250	329	416	509	612	726	847
Air Consumption (SLPM)	71.8	140	221	313	405	515	644	773	920	1068	1233	1417
Velocity (m/s)*	1.4	3.8	5.9	8	9.8	11.5	13.1	14.5	15.7	16.8	17.7	18.4

10012 / 10012S – 12" Standard Air Blade® Air Knife												
Inlet Pressure (PSIG)	10	20	30	40	50	60	70	80	90	100	110	120
Force (lbs)*	0	0.1	0.22	0.36	0.52	0.7	0.87	1.11	1.34	1.6	1.87	2.16
Air Consumption (SCFM)	4.6	7.2	11.1	14	19	23	23	33	39	46	52	59
Velocity (ft/s)*	6.3	12.5	18.3	23.5	28.3	32.5	36.1	39.3	42	44.2	45.8	47
Inlet Pressure (BAR)	0.7	1.4	2.1	2.8	3.5	4.2	4.9	5.6	6.2	6.9	7.7	8.4
Force (grams)*	2.18	43.5	100	163	235	316	405	503	610	725	849	982
Air Consumption (SLPM)	128.8	202	313	405	534	663	791	939	1104	1288	1472	1657
Velocity (m/s)*	1.9	3.8	5.6	7.2	8.6	9.9	11	12	12.8	13.5	14	14.3

PERFORMANCE CHARTS

10018 / 10018S – 18" Standard Air Blade® Air Knife												
Inlet Pressure (PSIG)	10	20	30	40	50	60	70	80	90	100	110	120
Force (lbs)*	0.03	0.17	0.32	0.51	0.72	0.93	1.17	1.43	1.7	2	2.31	2.64
Air Consumption (SCFM)	7.2	11	16	20	25	31	36	43	49	57	64	72
Velocity (ft/s)*	8.4	13.7	18.6	22.9	26.7	30	32.8	35	36.8	38	38.8	38.9
Inlet Pressure (BAR)	0.7	1.4	2.1	2.8	3.5	4.2	4.9	5.6	6.2	6.9	7.7	8.4
Force (grams)*	15.24	78.4	146	233	324	422	531	647	773	906	1049	1197
Air Consumption (SLPM)	202	313	442	571	718	865	1031	1215	1399	1601	1804	2025
Velocity (m/s)*	2.6	4.2	5.7	7	8.1	9.1	10	10.7	11.2	11.6	11.8	11.9

10024 / 10024S – 24" Standard Air Blade® Air Knife												
Inlet Pressure (PSIG)	10	20	30	40	50	60	70	80	90	100	110	120
Force (lbs)*	0.01	0.28	0.48	0.7	0.94	1.2	1.48	1.78	2.09	2.43	2.78	3.16
Air Consumption (SCFM)	10	15	20	26	32	38	45	52	59	67	75	84
Velocity (ft/s)*	9.8	14.6	19	22.9	26.2	29.1	31.4	33.2	34.5	35.5	35.5	35.3
Inlet Pressure (BAR)	0.7	1.4	2.1	2.8	3.5	4.2	4.9	5.6	6.2	6.9	7.7	8.4
Force (grams)*	45.72	128.5	220	318	427	544	671	806	949	1102	1263	1433
Air Consumption (SLPM)	294	423	571	736	902	1068	1270	1472	1675	1896	2135	2374
Velocity (m/s)*	3	4.5	5.8	7	8	8.9	9.6	10.1	10.5	10.8	10.8	10.8

10030 / 10030S – 30" Standard Air Blade® Air Knife												
Inlet Pressure (PSIG)	10	20	30	40	50	60	70	80	90	100	110	120
Force (lbs)*	0.2	0.42	0.66	0.92	1.2	1.5	1.81	2.16	2.52	2.89	3.28	3.7
Air Consumption (SCFM)	14	19	25	31	38	46	53	61	70	78	87	97
Velocity (ft/s)*	10.7	15.3	19.4	23	26	28.6	30.7	32.2	33.2	33.7	33.7	33.2
Inlet Pressure (BAR)	0.7	1.4	2.1	2.8	3.5	4.2	4.9	5.6	6.2	6.9	7.7	8.4
Force (grams)*	89.27	189.4	300	418	544	681	823	978	1141	1311	1489	1676
Air Consumption (SLPM)	387	534	699	883	1086	1288	1491	1730	1969	2209	2466	2742
Velocity (m/s)*	3.3	4.7	5.9	7	7.9	8.7	9.3	9.8	10.1	10.3	10.3	10.1

10036 / 10036S – 36" Standard Air Blade® Air Knife												
Inlet Pressure (PSIG)	10	20	30	40	50	60	70	80	90	100	110	120
Force (lbs)*	0.33	0.59	0.87	1.17	1.49	1.83	2.19	2.57	2.97	3.38	3.82	4.27
Air Consumption (SCFM)	16	23	29	37	44	53	61	70	79	89	99	109
Velocity (ft/s)*	11.4	15.8	19.7	23.1	26	28.4	30.2	31.6	32.4	32.7	32.5	31.8
Inlet Pressure (BAR)	0.7	1.4	2.1	2.8	3.5	4.2	4.9	5.6	6.2	6.9	7.7	8.4
Force (grams)*	148.05	265.6	394	531	677	830	993	1165	1346	1533	1731	1938
Air Consumption (SLPM)	460	644	828	1049	1252	1491	1730	1988	2246	2522	2816	3092
Velocity (m/s)*	3.5	4.8	6	7.1	7.9	8.7	9.2	9.6	9.9	10	9.9	9.7

Velocity is important in that it can determine the cooling effect and to some extent is related to the blowoff force. Velocity will vary significantly depending on the temperature of the ambient air the hotter the air, the greater the velocity (and the greater the amplification of air flow) so velocity figures at best are an approximation. As air is entrained, the flow increases and as the flow increases the velocity must come down.

The velocity at the exit of the Standard Air Blade® Air Knife is obviously the highest but the figure is of no real value as once the surrounding air is entrained, the velocity drops dramatically. (Be very wary of extremely high velocity claims downstream of any Air Knife). The figures we provide can be verified with a velocity meter. There will be variations in measurement due to air pressure, and atmospheric conditions. The velocity is, among these other things dependent on the chamber pressure. That pressure in turn depends upon pipe size, pressure drops in the system, distance from the compressor station to the use point, and many other factors.

CALCULATING AIR SAVINGS

To obtain the air consumption of drilled holes in pipe, determine the size of the holes and multiply the air loss by the number of holes over the length. The air consumption of the standard air blade® air knife is read off the performance tables.

EXAMPLE:

Assume an existing blowoff of a 30" long pipe with 3/32" holes spaced equally apart for a total of 40 holes. At 80 PSIG, from the graph, each hole consumes about 9.4 SCFM for a total of 40 X 9.4 = 376 SCFM.

At 80 PSIG, a 30" standard air blade air knife consumes 61 SCFM (from the performance chart). Compressed air saved is 376 - 61 = 315 SCFM.

Using actual air costs if known (or assuming a reasonable cost of \$0.30 US per 1000 cubic feet) the dollars saved is 315 X 60 X 0.30/1000 = \$5.67 per hour or assuming a 2000 hour working year = \$11340.00 US funds saved annually.

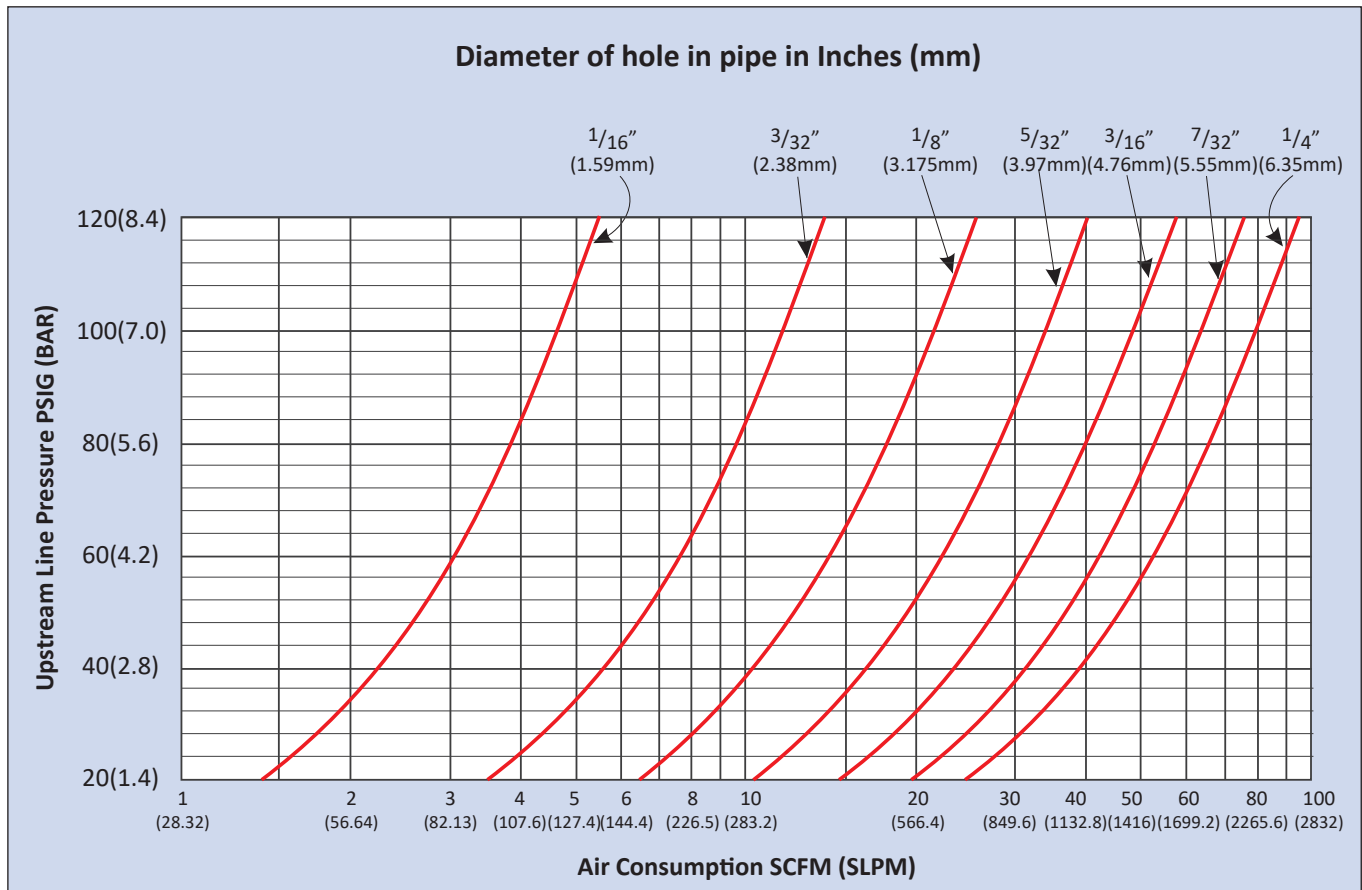

ALUMINUM STANDARD AIR BLADE® AIR KNIFE

PART NO.	DESCRIPTION
10003	3" Aluminum Standard Full-Flow Air Blade® Air Knife Only
10006	6" Aluminum Standard Full-Flow Air Blade® Air Knife Only
10008	8" Aluminum Standard Full-Flow Air Blade® Air Knife Only
10012	12" Aluminum Standard Full-Flow Air Blade® Air Knife Only
10018	18" Aluminum Standard Full-Flow Air Blade® Air Knife Only
10024	24" Aluminum Standard Full-Flow Air Blade® Air Knife Only
10030	30" Aluminum Standard Full-Flow Air Blade® Air Knife Only
10036	36" Aluminum Standard Full-Flow Air Blade® Air Knife Only
11003	3" Aluminum Standard Full-Flow Air Blade® Air Knife Only plus Filter with Auto Drain
11006	6" Aluminum Standard Full-Flow Air Blade® Air Knife Only plus Filter with Auto Drain
11008	8" Aluminum Standard Full-Flow Air Blade® Air Knife Only plus Filter with Auto Drain
11012	12" Aluminum Standard Full-Flow Air Blade® Air Knife Only plus Filter with Auto Drain
11018	18" Aluminum Standard Full-Flow Air Blade® Air Knife Only plus Filter with Auto Drain
11024	24" Aluminum Standard Full-Flow Air Blade® Air Knife Only plus Filter with Auto Drain
11030	30" Aluminum Standard Full-Flow Air Blade® Air Knife Only plus Filter with Auto Drain
11036	36" Aluminum Standard Full-Flow Air Blade® Air Knife Only plus Filter with Auto Drain
12003	3" Aluminum Standard Full-Flow Air Blade® Air Knife Only + Filter with Auto Drain + Regulator with gauge
12006	6" Aluminum Standard Full-Flow Air Blade® Air Knife Only + Filter with Auto Drain + Regulator with gauge
12008	8" Aluminum Standard Full-Flow Air Blade® Air Knife Only + Filter with Auto Drain + Regulator with gauge
12012	12" Aluminum Standard Full-Flow Air Blade® Air Knife Only + Filter with Auto Drain + Regulator with gauge
12018	18" Aluminum Standard Full-Flow Air Blade® Air Knife Only + Filter with Auto Drain + Regulator with gauge
12024	24" Aluminum Standard Full-Flow Air Blade® Air Knife Only + Filter with Auto Drain + Regulator with gauge
12030	30" Aluminum Standard Full-Flow Air Blade® Air Knife Only + Filter with Auto Drain + Regulator with gauge
12036	36" Aluminum Standard Full-Flow Air Blade® Air Knife Only + Filter with Auto Drain + Regulator with gauge

EXTRA STAINLESS STEEL SHIMS STANDARD AIR BLADE® AIR KNIFE (.002" or .050 mm Thick)

PART NO.	DESCRIPTION	PART NO.	DESCRIPTION
10103S	3" Stainless Steel Shim	10118S	18" Stainless Steel Shim
10106S	6" Stainless Steel Shim	10124S	24" Stainless Steel Shim
10108S	8" Stainless Steel Shim	10130S	30" Stainless Steel Shim
10112S	12" Stainless Steel Shim	10136S	36" Stainless Steel Shim

NOTE: Plastic shims can wear out quickly in Air Knives if the air is not clean. Nex Flow® uses ONLY stainless steel shims.

STAINLESS STEEL STANDARD AIR BLADE® AIR KNIFE

PART NO.	DESCRIPTION
10003S	3" Stainless Steel Standard Full-Flow Air Blade® Air Knife Only
10006S	6" Stainless Steel Standard Full-Flow Air Blade® Air Knife Only
10012S	12" Stainless Steel Standard Full-Flow Air Blade® Air Knife Only
10018S	18" Stainless Steel Standard Full-Flow Air Blade® Air Knife Only
10024S	24" Stainless Steel Standard Full-Flow Air Blade® Air Knife Only
10030S	30" Stainless Steel Standard Full-Flow Air Blade® Air Knife Only
10036S	36" Stainless Steel Standard Full-Flow Air Blade® Air Knife Only
11003S	3" Stainless Steel Standard Full-Flow Air Blade® Air Knife Only plus Filter with Auto Drain
11006S	6" Stainless Steel Standard Full-Flow Air Blade® Air Knife Only plus Filter with Auto Drain
11012S	12" Stainless Steel Standard Full-Flow Air Blade® Air Knife Only plus Filter with Auto Drain
11018S	18" Stainless Steel Standard Full-Flow Air Blade® Air Knife Only plus Filter with Auto Drain
11024S	24" Stainless Steel Standard Full-Flow Air Blade® Air Knife Only plus Filter with Auto Drain
11030S	30" Stainless Steel Standard Full-Flow Air Blade® Air Knife Only plus Filter with Auto Drain
11036S	36" Stainless Steel Standard Full-Flow Air Blade® Air Knife Only plus Filter with Auto Drain
12003S	3" Stainless Steel Standard Full-Flow Air Blade® Air Knife Only + Filter with Auto Drain + Regulator with gauge
12006S	6" Stainless Steel Standard Full-Flow Air Blade® Air Knife Only + Filter with Auto Drain + Regulator with gauge
12012S	12" Stainless Steel Standard Full-Flow Air Blade® Air Knife Only + Filter with Auto Drain + Regulator with gauge
12018S	18" Stainless Steel Standard Full-Flow Air Blade® Air Knife Only + Filter with Auto Drain + Regulator with gauge
12024S	24" Stainless Steel Standard Full-Flow Air Blade® Air Knife Only + Filter with Auto Drain + Regulator with gauge
12030S	30" Stainless Steel Standard Full-Flow Air Blade® Air Knife Only + Filter with Auto Drain + Regulator with gauge
12036S	36" Stainless Steel Standard Full-Flow Air Blade® Air Knife Only + Filter with Auto Drain + Regulator with gauge

EXTRA STAINLESS STEEL SHIMS STANDARD AIR BLADE® AIR KNIFE (.002" or .050 mm Thick)

PART NO.	DESCRIPTION
10103S	3" Stainless Steel Shim
10106S	6" Stainless Steel Shim
10112S	12" Stainless Steel Shim
10118S	18" Stainless Steel Shim

PART NO.	DESCRIPTION
10124S	24" Stainless Steel Shim
10130S	30" Stainless Steel Shim
10136S	36" Stainless Steel Shim

NOTE: Plastic shims can wear out quickly in Air Knives if the air is not clean. Nex Flow® uses ONLY stainless steel shims.