

## AIR NOZZLES AND JETS

Superior designed Air Nozzle and Jets reduce compressed air consumption and noise levels while maintaining Laminar Flow for Strong Blowoff

### WHAT ARE THEY - REASONS TO USE

Air Nozzles are the smallest air amplifiers for point applications. There are two types: and aspirator or coned shaped type and so-called star-shaped profiles. The aspirator types provide greater flow amplification, ideal for cooling but have a lower force/air consumption ratio than star-shaped versions. So when higher force is more important, the star profile versions are the best choice.

Air Jets entrain large volumes of surrounding air through the Jet (similar to air amplifiers) and are more efficient than Air Nozzles because of their larger size. The larger the “air amplification nozzle or jet” the greater the efficiency for flow amplification although larger star profile nozzles can give a higher force/air consumption ratio.

The most important reasons to use Air Amplification Nozzles and Jets apart from energy reduction is safety and reduced noise levels. All Nex Flow® Air Nozzles and Jets meet OSHA standard CFR 1910.242 (b) for dead end pressure. Noise levels are dramatically reduced up to 10dBA along with lower energy consumption.



The Nex Flow® Air Mag® “patent pending” star profile air amplifying nozzle has the best force/air consumption ratio known. Ideal when higher force required in blowoff applications.

**Nex Flow®** Nozzles and Jets: Our range of nozzles can address most valid applications for blowoff and cooling.

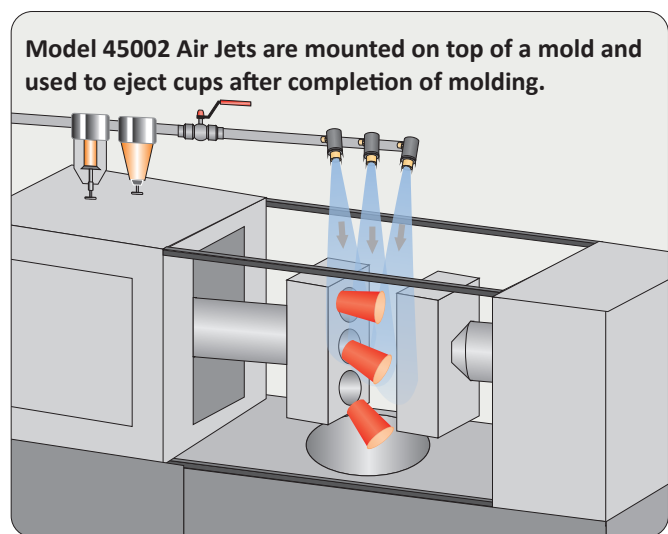
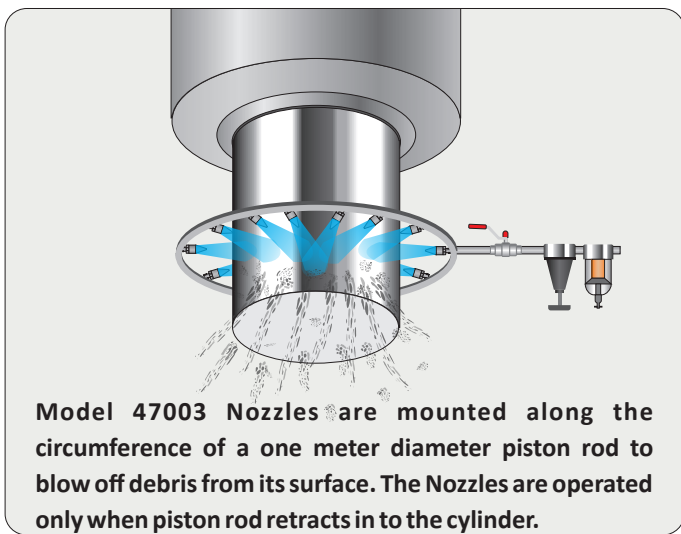

**HOW IT WORKS**

Air Mag® nozzle Model 47004AMF – Compressed air enters at point (A). Surrounding air (B) is entrained over the specially designed surface profile as the small amount of compressed air exits the specially designed holes drilled in the nozzle and combines at (C) to form a concentrated high velocity, laminar flow stream of amplified air flow and concentrated force with very high ratio of force/cfm.

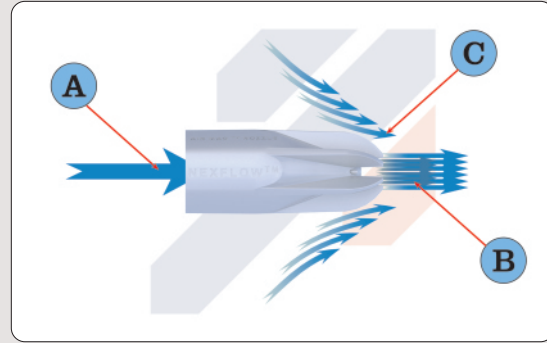

**HOW IT WORKS**

Air Nozzle - Models 47001, 47002, 47003, 47003S, 47003S-316L, 47004, 47004S, 47004S-316L, 47004F, 47004FS, 47004FS-316L, 47009, 47009S, 47009S-316L Compressed air enters at point (A). Surrounding air (B) is entrained over a specially designed profile surface by the action of the small amount of compressed air leaving the ring gap at point (C). This results in a concentrated high velocity, laminar flow stream of amplified air with maximized force.

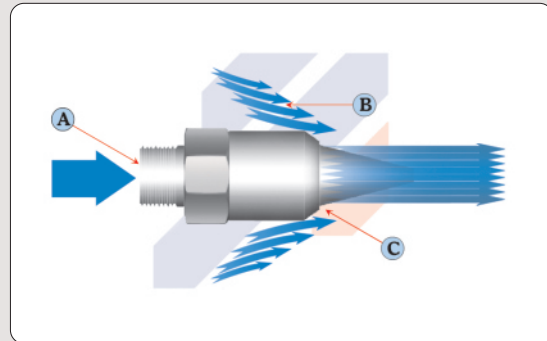

**HOW IT WORKS**

X-stream® Air Nozzle - Model 47010 - Compressed air enters at point (A). Surrounding air (B) is entrained over a specially designed profile surface by the action of the small amount of compressed air leaving the small drilled holes at point (C). This results in a concentrated high velocity, laminar flow stream of amplified air with maximized force.

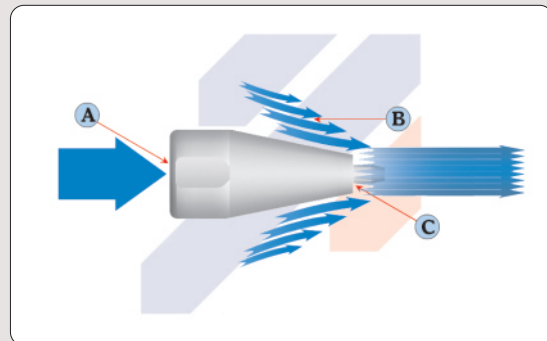

**AIR NOZZLE**

PART NO.	DESCRIPTION
47004AMF	Cast Zinc high force/air consumption efficiency Air Mag® nozzle - ¼" female NPT or BSP
47001	Brass Mini Nozzle with 10/32 fitting or metric equivalent
47002	Brass Mini Nozzle with copper tube - male
47003	Standard Aluminum 1/8" NPT or BPS male fitting
47003S	Standard 303/304 Stainless Steel 1/8" NPT or BPS male fitting
47003S-316L	Standard 316L Stainless Steel 1/8" NPT or BPS male fitting
47004	Extra Strong Aluminum 1/4" NPT or BPS male fitting
47004S	Standard 303/304 Stainless Steel 1/4" NPT or BPS male fitting
47004S-316L	Standard 316L Stainless Steel 1/4" NPT or BPS male fitting
47004F	Extra Strong Aluminum 1/4" NPT or BPS female fitting
47004FS	Standard 303/304 Stainless Steel 1/4" NPT or BPS female fitting
47004F-316L	Standard 316L Stainless Steel 1/4" NPT or BPS female fitting
47009	Adjustable Aluminum Nozzle with 1/8" male NPT or BPS fitting
47009S	Standard 303/304 Stainless Steel 1/8" NPT or BPS male fitting
47009S-316L	Standard 316L Stainless Steel 1/8" NPT or BPS male fitting
47010	X-Stream® Anodized Aluminum Strong Force Nozzle with ¼" female NPT or BPS fitting



**THE NEX FLOW® AIR MAG® NOZZLES**



The “Patent Pending” NEX FLOW® AIR MAG® NOZZLE is extremely efficient in producing a higher force/unit of air consumption because of its unique design utilizing small diameter air exit holes to concentrate the air flow from the other holes, along with entrained air to produce a high force at the target. This design also extends the distance for laminar flow allowing greater flexibility in use at a distance. It even out performed so-called laval type nozzles and does not have the annoying whistling sound that might occur with such designs.

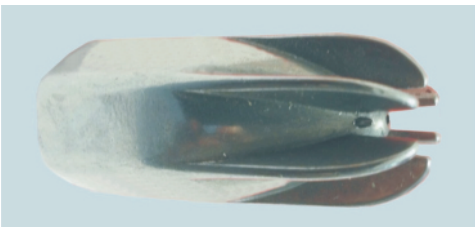

**Model 47004AMF** – is the first product of the **The Nex Flow® Air Mag®** “patent pending” star profile air amplifying nozzle and has the best force/air consumption ratio known. Ideal when higher force required in blowoff applications.

**Sound Level 78 dBA at 3 ft. (0,91m) at 80 psig (5.5 bar)**

**HOW TO PROVE FOR YOURSELF HOW GOOD A NOZZLE IS?**

The Nex Flow® Air Mag® nozzle is designed so that the force at a particular pressure will be approximately the same as competitive nozzle of star type profile design. To compare and prove the superiority of the Nex Flow® Air Mag® nozzle this makes it easy by simply replacing the other nozzle and seeing what happens. To do this, have a pressure regulator and gauge upstream. And if possible a flow meter upstream. Either have a scale to blow against or just apply it your particular application. For each nozzle, adjust the pressure upstream to that it is the same for all nozzles tested. This is what you can expect.....

If you replace any competitive nozzle, you will probably have to cut back the pressure as you will get more force from the Nex Flow® Air Mag® nozzle. This is because the air consumption is “less” at any given pressure which also means less pressure drop in the line as the air flows out through the nozzle. So you will actually be getting a bit more pressure and force as a result. You can then cut back the pressure if not needed thereby reducing compressed air use even more.

If you have a flow meter, all nozzles can be tested comparatively.

Alternatively, you can just try the various nozzles and you will find the Nex Flow® Air Mag® nozzle to perform better simply because there is less pressure drop since it uses less compressed air, indicating its greater efficiency.

**When Power is Needed the Air Mag® nozzle is at the Leading Edge of All Other Air Nozzle Designs:**

- 1.) Thick fins and calculated geometry on the outer body makes the nozzle more safe and sturdy for industrial environments as the air exit holes cannot be blocked by hand( Meets OSHA regulations on dead end pressure)
- 2.) Compact 1 piece design for greater strength specifically designed to withstand industrial environments and mo worker friendly i.e no chance for breaking or exploding like 2 piece designs.
- 3.) Elegant sleek design for a better Coanda effect with engineered surface to provide laminar flow and high velocity with lower air consumption
- 4.) Patented hole design allows for the compressed air to exit with greater efficiency and reduced turbulence allowing the air to reach the target with zero drag.
- 5.) 10-20% more force per unit of air consumption compared with competitors and usable at greater distance due to high concentration of air flow and patented design.
- 6.) Engineered body design reduces the noise level by entraining the surrounding air and producing a lower exhaust noise level.
- 7.) Concentrated flow to reach long distances Workable at greater distances than competitive air nozzles Ideal for cleaning CNC machines where metal chips could bounce back on the face or in breathing in wood working router produced dust if too close.
- 8.) Special outer shape and widely spaced fins allows for easy cleaning and buffed surface minimizes the sticking and collecting of dust an dirt.
- 9.) Precise machined threads, rugged design and the material quality means long life and unlikely to break.
- 10.) Especially ideal for point applications in which a nozzle is required to target a specific part at greater distance yet with a wide enough flow profile and force to equal that of competitive nozzles at a greater distance.

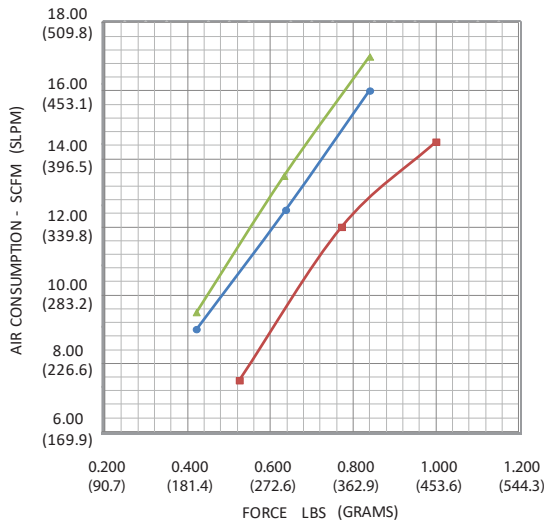

**FORCE EFFICIENCY OF THE NEX FLOW® MODEL 47004AMF AIR MAG® NOZZLE TO COMPETITIVE VERSIONS**

— NEX FLOW™ — EUROPEAN — N. AMERICAN

Note: Data for Force measured at 6". Data measurement was done at a college test laboratory utilizing accurate force and flow measurement equipment. All nozzles tested under the same conditions. Published data was not used - only actual measurements made in the lab.

Note: Data for Force measured at 6"

INPUT LINE PRESSURE PSIG (BAR)	NEX FLOW® AIR MAG® NOZZLE		EUROPEAN STAR TYPE DESIGN		NORTH AMERICAN STAR TYPE DESIGN	
	Force-Lbs (Force-gms)	SCFM (SLPM)				
<b>40</b> (2.8)	.525 (238)	7.5 (212)	.421 (191)	9.0 (255)	.421 (191)	9.5 (269)
<b>60</b> (4.1)	.772 (350)	12.0 (340)	.637 (289)	12.5 (354)	.633 (287)	13.5 (382)
<b>80</b> (5.5)	1.00 (454)	14.5 (411)	.840 (381)	16.0 (453)	.840 (381)	17.0 (481)

**ADVANTAGES OF THE AIR MAG® DESIGN**

- . Lowest air consumption for force produced
- . lower noise levels
- . no whistling sound
- . single piece design for extra strength



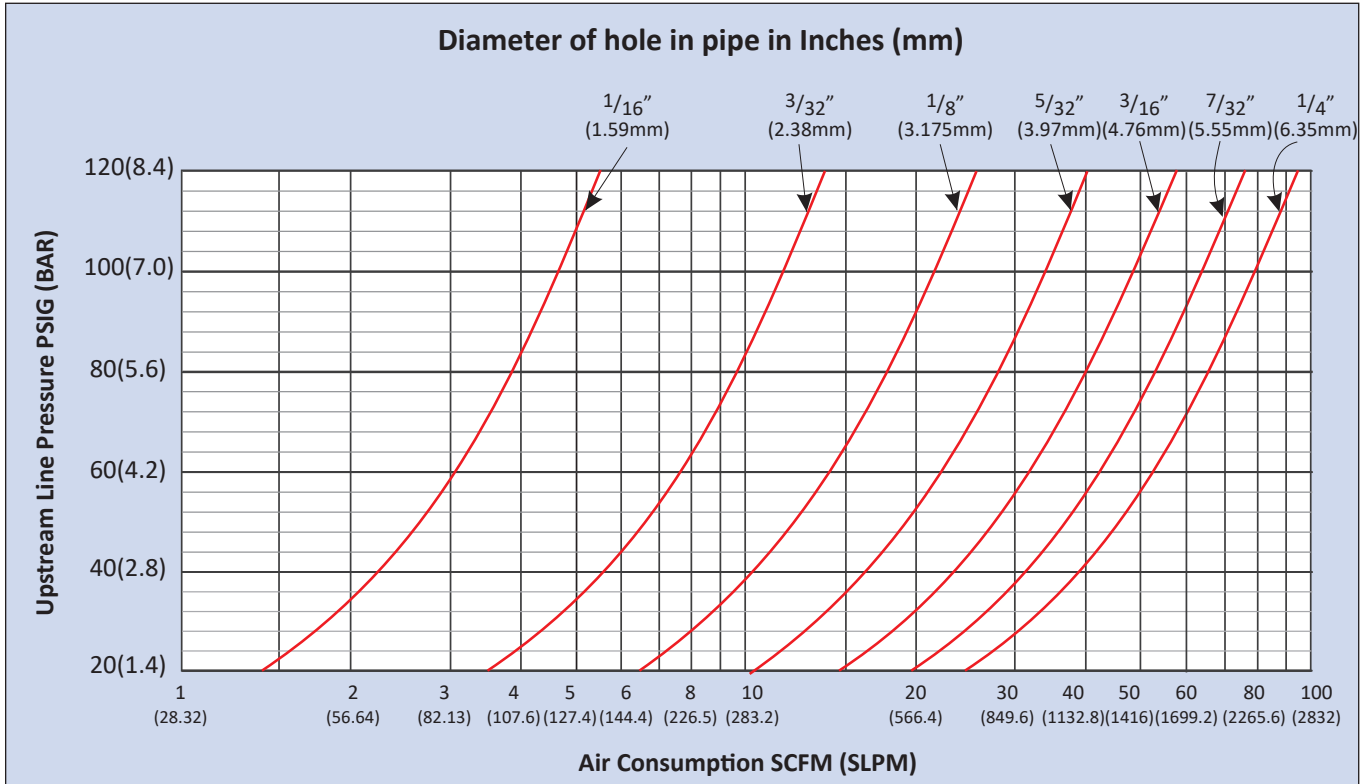

Open tubes and pipe create a great deal of noise due to the energy loss from turbulent flow. Not only is there a great deal of compressed air used, the flow is mostly turbulent so the force required for many blow off applications can dissipate quickly and become weak after only a few inches from the opening.

Engineered air nozzles recover much of the energy wasted as noise and pressure drop to produce a more focused, laminar flow that not only saves energy and reduces noise, but also provides a useful blow off force at a much greater distance from the target.

In addition, the "amplified" flow due to air entrained is a much higher volume that is ideal for cooling small areas.

**PERFORMANCE OF THE NEX FLOW® AIR MAG NOZZLES**

<b>AIR MAG NOZZLE - MODEL 47000AMS - 4mm.</b>						
<b>INLET PRESSURE PSIG (BAR)</b>	<b>20 (1.4)</b>	<b>40 (2.8)</b>	<b>60 (4.1)</b>	<b>80 (5.5)</b>	<b>100 (6.9)</b>	<b>120 (8.3)</b>
<b>FORCE LBS (GRAMS)</b>	0.888 (40)	0.154 (70)	0.229 (104)	0.300 (136)	0.336 (166)	0.430 (195)
<b>AIR CONSUMPTION SCFM (SLPM)</b>	0.5 (14)	1 (28)	2.5 (71)	3.5 (99)	5 (142)	6 (170)

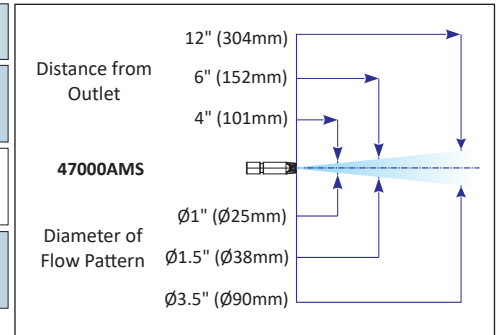

<b>AIR MAG NOZZLE - MODEL 47001AMS - 5mm.</b>						
<b>INLET PRESSURE PSIG (BAR)</b>	<b>20 (1.4)</b>	<b>40 (2.8)</b>	<b>60 (4.1)</b>	<b>80 (5.5)</b>	<b>100 (6.9)</b>	<b>120 (8.3)</b>
<b>FORCE LBS (GRAMS)</b>	0.168 (76)	0.320 (145)	0.463 (210)	0.631 (286)	0.772 (350)	0.838 (380)
<b>AIR CONSUMPTION SCFM (SLPM)</b>	2 (57)	4.5 (128)	6.5 (184)	8 (227)	10 (283)	12 (340)

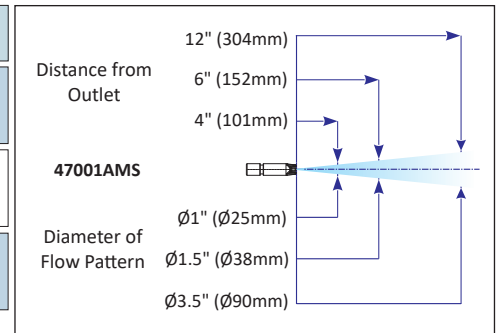

<b>AIR MAG NOZZLE - MODEL 47002AMS - 6mm.</b>						
<b>INLET PRESSURE PSIG (BAR)</b>	<b>20 (1.4)</b>	<b>40 (2.8)</b>	<b>60 (4.1)</b>	<b>80 (5.5)</b>	<b>100 (6.9)</b>	<b>120 (8.3)</b>
<b>FORCE LBS (GRAMS)</b>	0.265 (120)	0.496 (225)	0.728 (330)	0.948 (430)	1.120 (510)	1.320 (600)
<b>AIR CONSUMPTION SCFM (SLPM)</b>	5 (142)	8 (227)	11 (311)	14 (396)	17 (481)	20 (566)

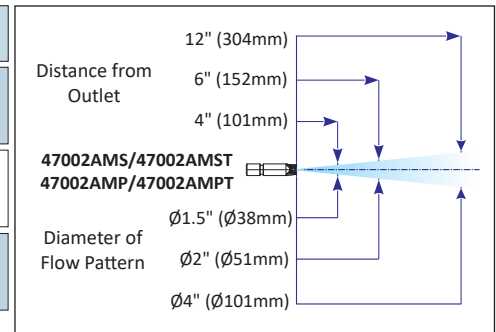

<b>AIR MAG NOZZLE - MODEL 47004AMF/47004AMFS - 1/4"</b>						
<b>INLET PRESSURE PSIG (BAR)</b>	<b>20 (1.4)</b>	<b>40 (2.8)</b>	<b>60 (4.1)</b>	<b>80 (5.5)</b>	<b>100 (6.9)</b>	<b>120 (8.3)</b>
<b>FORCE LBS (GRAMS)</b>	0.264 (120)	0.525 (238)	0.772 (350)	1.00 (454)	1.10 (500)	1.34 (610)
<b>AIR CONSUMPTION SCFM (SLPM)</b>	5 (142)	7.5 (212)	12 (340)	14.5 (411)	16 (453)	18 (510)

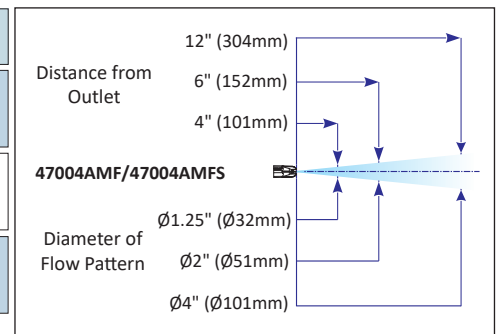

<b>AIR MAG NOZZLE - MODEL 47006AMF/47006AMFS - 1/2"</b>						
<b>INLET PRESSURE PSIG (BAR)</b>	<b>20 (1.4)</b>	<b>40 (2.8)</b>	<b>60 (4.1)</b>	<b>80 (5.5)</b>	<b>100 (6.9)</b>	<b>120 (8.3)</b>
<b>FORCE LBS (GRAMS)</b>	1.06 (480)	2.03 (920)	2.98 (1350)	3.92 (1780)	4.63 (2100)	5.07 (2300)
<b>AIR CONSUMPTION SCFM (SLPM)</b>	21 (510)	33.5 (949)	45 (1274)	54.5 (1543)	62 (1756)	68 (1925)

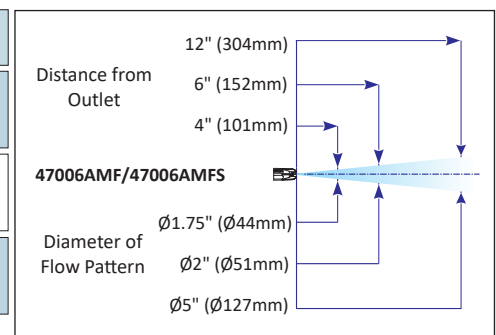

**AIR NOZZLES:**

Nex Flow® Nozzle are designed to fit into small spaces. We have an adjustable Nozzle for some applications and then a few different Nozzles with varying force, depending on the application.



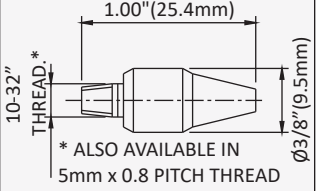

1.00" (25.4mm)  
10-32" THREAD\*  
\* ALSO AVAILABLE IN 5mm x 0.8 PITCH THREAD  
Ø3/8" (9.5mm)

**Model 47001** - Is a small brass Nozzle to fit into small spots and used by many machine builders for blowoff applications.  
Sound level 74 dBA at 3ft (0.91 m) at 80 psig (5.6 bar).



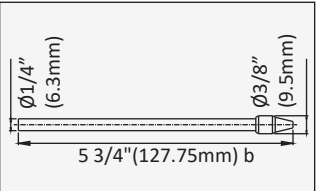

Ø1/4" (6.3mm)  
5 3/4" (127.75mm) b  
Ø3/8" (9.5mm)

**Model 47002** - Is the small Model 47001 brass Nozzle added to a copper tube. Machine builders can bend the copper tube and aim the nozzles to where ever it suits. The copper tube is simply press fit into the customer's system.  
Sound level 74 dBA at 3ft (0.91 m) at 80 psig (5.6 bar).



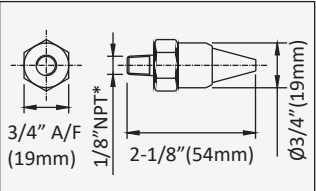

3/4" A/F (19mm)  
1/8" NPT\*  
2-1/8" (54mm)  
Ø3/4" (19mm)

**Model 47003 (anodized aluminum), 47003S (303/304 stainless steel), 47003S-316L (316L stainless steel)** -  
Is a common standard strength nozzle with a 1/8" male NPT connection and ideal for most blow-off applications involving liquids. It is made of aluminum (or stainless steel) and is partially anodized for longer life. The coanda profile is made for excellent noise reduction and blow-off force at a good distance  
Sound level 77 dBA at 3ft (0.91 m) at 80 psig (5.6 bar).



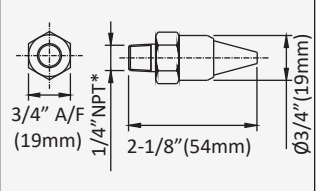

3/4" A/F (19mm)  
1/4" NPT\*  
2-1/8" (54mm)  
Ø3/4" (19mm)

**Model 47004 (anodized aluminum), 47004S (303/304 stainless steel), 47004S-316L (316L stainless steel)** -  
Is another common but stronger force nozzles with a 1/4" male NPT connection and ideal for most blow-off applications involving liquids and even light weight parts. It is made of aluminum (or stainless steel) and is partially anodized for longer life. Again the coanda profile is made for excellent noise reduction and blow-off force at a good distance.  
Sound level 78 dBA at 3ft (0.91 m) at 80 psig (5.6 bar).



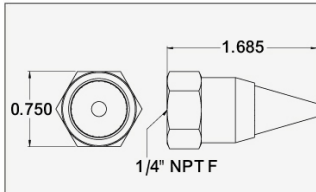

0.750  
1.685  
1/4" NPT F

**Model 47004F (anodized aluminum), 47004FS (303/304 stainless steel), 47004FS-316L (316L stainless steel)** -  
Is another common but stronger force nozzles with a 1/4" female NPT connection and ideal for most blow-off applications involving liquids and even light weight parts. It is made of aluminum (or stainless steel) and is partially anodized for longer life. Again the coanda profile is made for excellent noise reduction and blow-off force at a good distance.  
Sound level 78 dBA at 3ft (0.91 m) at 80 psig (5.6 bar).



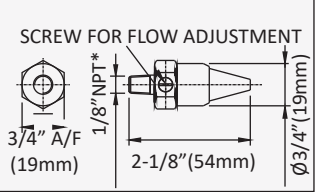

SCREW FOR FLOW ADJUSTMENT  
3/4" A/F (19mm)  
1/8" NPT\*  
2-1/8" (54mm)  
Ø3/4" (19mm)

**Model 47009 (anodized aluminum), 47009S (303/304 stainless steel), 47009S-316L (316L stainless steel)** -  
Is similar to the 47003 except it is made adjustable. The Superior design of the adjustable set screw is made to adjust the nozzles within its weakest and strongest ranges.

**AIR NOZZLES:**

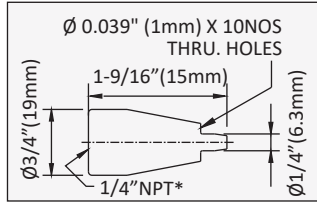

**Model 47010** - Is a unique design by Nex Flow® and is extremely powerful. It has a 1/4" female NPT fitting and is fully anodized for long life. With the 'coanda' profile you get an extremely strong force at a distance. This is an ideal Nozzle for blow guns and for blowing small parts for part ejection heavier viscosity liquids. The 47010 is a higher force Nozzle but has less distance for laminar flow than the 47004. Use the Model 47004 is greater distance required from the Nozzle.

Sound level 78 dBA at 3ft (0.91 m) at 80 psig (5.6 bar).

**\*BSP Threads or Adaptors can be supplied depending on country location.**

**PERFORMANCE CHARTS :**

MODEL	DESCRIPTION	AIR CONSUMPTION @80 PSIG	FORCE IN OUNCES	FORCE IN GRAMS	dBA @80PSIG (5.6 bar)
47001	Brass Mini-Nozzle with 10/32 fitting or metric equivalent	6.0	5.0	142	74
47002	Brass Mini-Nozzle with copper tube Male Connection	6.0	5.0	142	74
47003 (aluminium) 47003S (303/304 stainless) 47003S-316L (316L stainless)	Standard aluminium 1/8" NPT Male Connection	11.2	8.0	227	77
47003SM (316L Stainless)	1/8" NPT Mini Nozzle	18.5	14.6	415	77
47004 (aluminium) 47004S (303/304 stainless) 47004S-316L (316L stainless)	Extra Strong aluminium 1/4" NPT Male Connection	24.0	21.0	596	78
47004F (aluminium) 47004FS (303/304 stainless) 47004FS-316L (316L stainless)	Extra Strong aluminium 1/4" NPT Female Connection	24.0	21.0	596	78
47009 (aluminium) 47009S (303/304 Stainless) 47009S-316L (316L stainless)	Adjustable Aluminium Nozzle 1/8" NPT Male Connection	Maximum 24.0	Maximum 23.0	653	77
	can be set to minimum and maximum with set screw	Minimum 13.0	Minimum 13.0	369	77
47010	X-Stream® Strong Force Nozzle 1/4" NPT Female Connection	21.2	21.7	615	78
47004AMF	Air Mag® Nozzle 1/4" NPT Female Connection	15.5	15.0	425	78
47011-4	Air Edger® Flat Jet .004 gap setting	20.5	12	340	75



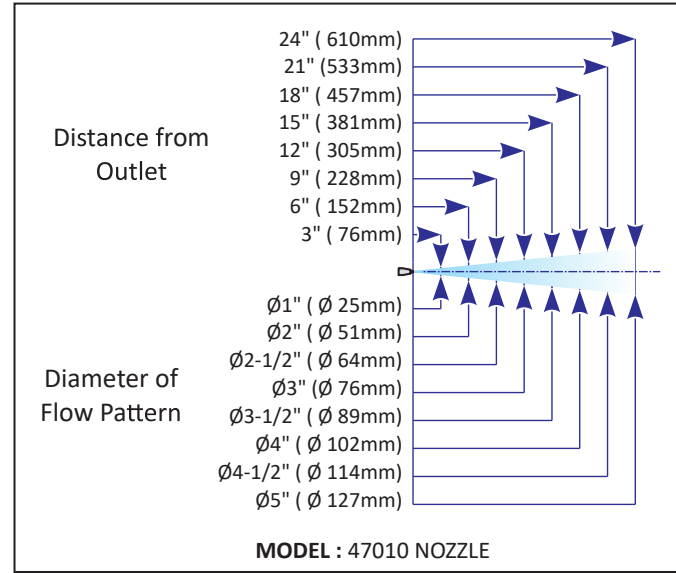
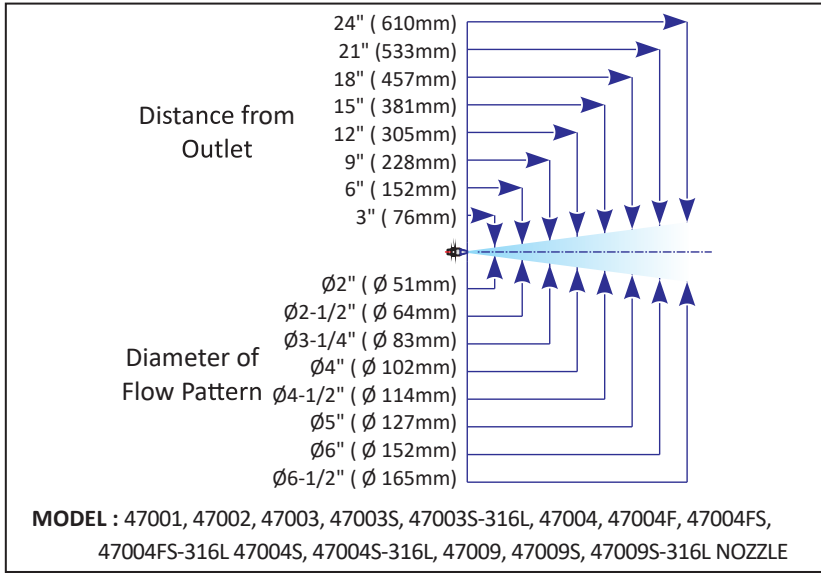

**AIR NOZZLES**

PART NO.	DESCRIPTION
47004AMF	Cast Zinc high force/air efficiency Air Mag® nozzle - 1/4" female NPT or BPS
47001	Brass Mini Nozzle with 10/32 fitting or metric equivalent
47002	Brass Mini Nozzle with copper tube - male
47003	Standard Aluminum 1/8" NPT or BPS male fitting
47003S	Standard 303/304 Stainless Steel 1/8" NPT or BPS male fitting
47003S-316L	Standard 316L Stainless Steel 1/8" NPT or BPS male fitting
47004	Extra Strong Aluminum 1/4" NPT or BPS male fitting
47004S	Standard 303/304 Stainless Steel 1/4" NPT or BPS male fitting
47004S-316L	Standard 316L Stainless Steel 1/4" NPT or BPS male fitting
47004F	Extra Strong Aluminum 1/4" NPT or BPS female fitting
47004FS	Standard 303/304 Stainless Steel 1/4" NPT or BPS female fitting
47004FS-316L	Standard 316L Stainless Steel 1/4" NPT or BPS female fitting
47009	Adjustable Aluminum Nozzle with 1/8" male NPT or BPS fitting
47009S	Standard 303/304 Stainless Steel 1/8" NPT or BPS male fitting
47009S-316L	Standard 316L Stainless Steel 1/8" NPT or BPS male fitting
47010	X-Stream® Anodized Aluminum Strong Force Nozzle with 1/4" female NPT or BPS fitting

**STAINLESS STEEL RIGID FLEX HOSE ( REFER TO PAGE E9 FOR THE RIGID FLEX HOSE )**

PART NO.	DESCRIPTION
6RF (MM / MF)	6" Stainless Steel Rigid Hose which can be flexed to a shape
12RF (MM / MF)	12" Stainless Steel Rigid Hose which can be flexed to a shape
18RF (MM / MF)	18" Stainless Steel Rigid Hose which can be flexed to a shape