

X-STREAM® RING VAC®

Convey solid materials, waste, trim, small parts with virtually no moving parts further with wear resistance

WHAT ARE THEY - REASONS TO USE

The Ring Vac® - Pneumatic Conveying System has virtually no moving parts, conveys material at high rates and over long distances. They utilize only compressed air for a powerful, efficient venturi action along its length in a compact design for high capacity conveying over large distances. Ring Vacs are available in both coated aluminum or stainless steel. Simply clamp a standard hose size to each end of the Ring Vac® to create this high energy conveying system. Threaded versions may be connected into standard pipe thread. No moving parts for maintenance free operation with capacity and flow controlled with a pressure regulator. Sizes are 3/8" (10mm), 1/2" (13mm), 3/4" (19mm), 1" (24.4mm), 1-1/4" (32mm), 1 1/2" (38mm) and 2" (51mm) and 3" (76.2mm). Any size beyond that can be prohibitive for most applications due to high compressed air requirements.

Beyond 3", the vacuum ability begins to drop significantly except for highly intermittent applications. However 3" units are available for such applications. Larger sizes are available on special order.

Anodized aluminum and high temperature stainless steel Ring Vac® air conveyor can convey all types of solids in large volumes over great distances with no moving parts.

APPLICATIONS:

- ▶ Hopper Loading
- ▶ Material Conveying
- ▶ Trim Removal
- ▶ Transfer Parts
- ▶ Filling Operations
- ▶ Thread/fiber Tensioning

HEAVY DUTY X-STREAM®RING VAC® BENEFITES:

- ▶ Longer life in difficult environments than competitive models.
- ▶ Ease of use.
- ▶ Simple and easy control of material flow.
- ▶ Maintenance free operation.



HEAVY DUTY X-STREAM® RING VAC® FEATURES:

- ▶ Made of Hard Anodized aluminum with no moving parts. Ideal for moving abrasive materials
- ▶ Extra strength to convey longer distances both vertically and horizontally than standard models.
- ▶ Utilizing a pressure regulator will control the flow of material
- ▶ Instant on/off with no moving parts, no electricity or explosion hazard

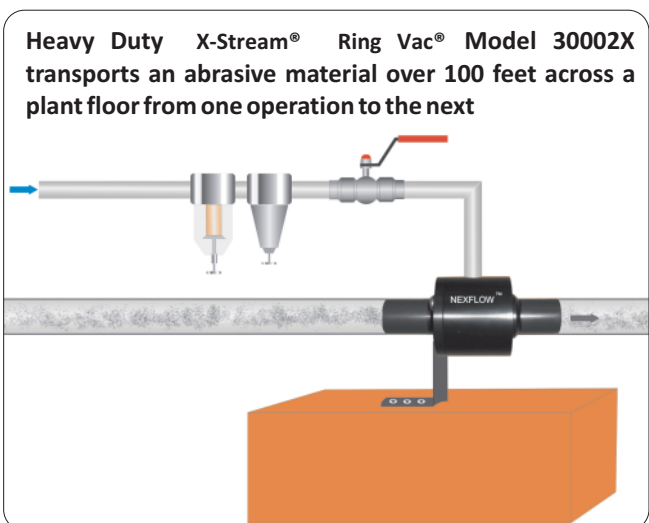

TYPES OF RING VACS

The Heavy Duty X-Stream® Ring Vac® Pneumatic Conveying System comes in hard anodized aluminum for abrasion resistance and with more power than the standard versions to convey greater vertical and horizontal distances. Regular models connect to a standard hose or tube to provide a powerful and simply in-line conveying system. Threaded versions thread directly into threaded pipe. The generator can be machined further for even larger capacities and distances although they can will use more compressed air.

An optional bracket allows form easy mounting.



SELECTION

The Heavy Duty X-Stream Ring Vac® is available in a wide variety of sizes depending on your application. There are certain criteria to determine the size you need:

- ▶ Diameter of the parts that need to be conveyed
- ▶ Rate required for conveying (by weight or volume)
- ▶ Diameter of the tube, pipe or hose used
- ▶ Material- Hard Anodized Aluminum



SPECIAL DESIGNS

The high temperature models are suited to temperatures up to 1200°F (650°C). One ideal use is for sampling flue gases. Special versions can be supplied with medical flanges, and specific materials, higher flow rates and vacuum depending on your application.

Heavy Duty X-Stream™ Ring Vac® - HOW IT WORKS: Ring-Vac® compressed air conveying system - Compressed air enters at point (A) into a annular plenum chamber and injected into the throat of the unit through directed nozzles. These jets of compressed air create a vacuum at the inlet (C) which draws in material and accelerates it through the unit and out at (D) conveying the material over a great vertical or horizontal distance.

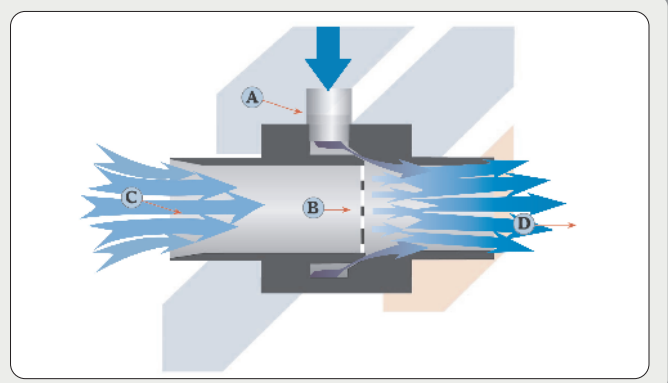

DIMENSIONS - NOTES ON PART NUMBERS:

T- threaded

Dimensions in inches and (mm)

PART NUMBER (aluminum & stainless)	A IN (MM)	B IN (MM)	C IN (MM)	D IN (MM)	E IN (MM)	F IN (MM)	G IN (MM)	H IN (MM)	I IN (MM)	J IN (MM)	K IN (MM)	L
30001X, 30001XT	1.00" (25.4)	1.38" (35.1)	1.50" (38.1)	4.88" (124.0)	2.24" (56.8)	0.75" (19.0)	2.17" (55.0)	0.73" (18.5)	0.39" (10.0)	1.58" (40.0)	1.97" (50.0)	1/4 NPT
30002X, 30002XT	1.25" (31.8)	1.38" (35.1)	1.50" (38.1)	4.88" (124.0)	2.49" (63.2)	1.00" (25.4)	2.21" (56.3)	0.73" (18.5)	0.39" (10.0)	1.77" (45.0)	2.17" (55.0)	1/4 NPT
30003X, 30003XT	1.50" (38.1)	1.38" (35.1)	1.50" (38.1)	4.88" (124.0)	2.75" (69.9)	1.125" (28.6)	2.15" (54.5)	0.89" (22.5)	0.39" (10.0)	1.58" (40.0)	1.97" (50.0)	3/8 NPT
30004X, 30004XT	2.00" (50.8)	1.38" (35.1)	1.50" (38.1)	4.88" (124.0)	3.21" (81.6)	1.75" (44.5)	2.39" (60.7)	1.18" (30.0)	0.39" (10.0)	1.58" (40.0)	1.97" (50.0)	3/8 NPT

Top View

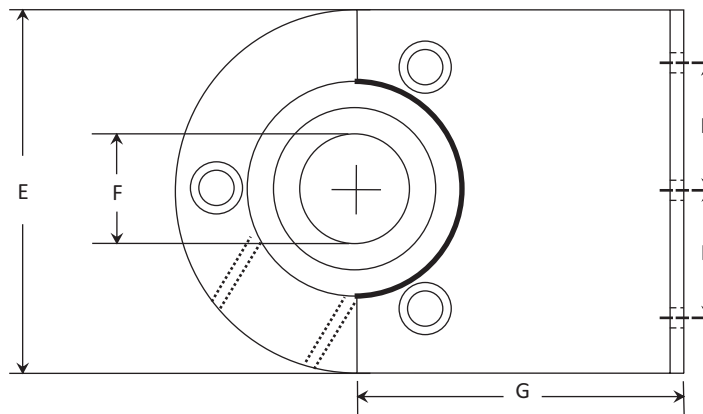

Series 30001X - 30004X

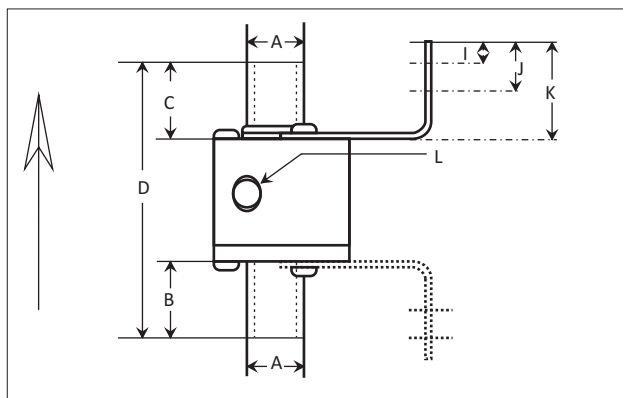

Series 30001XT - 30004XT Threaded

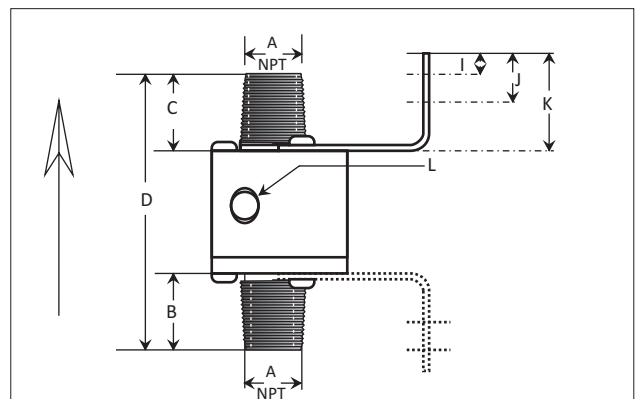

HEAVY DUTY X-STREAM® RING VAC® PNEUMATIC CONVEYING SYSTEM PERFORMANCE:

MODEL	SIZE OUTSIDE DIAMETER INCHES (MM)	AIR CONSUMPTION SCFM AT 80 PSIG (SLPM AT 5.5 BAR)	VACUUM INCHES H2O (KPA)
30001X, 30001XT	1" (25mm)	21 (595)	-60 (-15)
30002X, 30002XT	1 1/4" (32mm)	33 (934)	-55 (-14)
30003X, 30003XT	1-1/2" (38mm)	44 (1245)	-50 (-13)
30004X, 30004XT	2" (51mm)	58 (1642)	-36 (-9)

HEAVY DUTY X-STREAM® RING VAC® IN-LINE CONVEYERS

PART NO.	
30001X	1" X-Stream® Ring Vac® Only
30002X	1-1/4" Aluminum X-Stream® Ring Vac® Only
30003X	1-1/2" Aluminum X-Stream® Ring Vac® Only
30004X	2" Aluminum X-Stream® Ring Vac® Only
31001X	1" Aluminum X-Stream® Ring Vac® plus Filter with Auto Drain
31002X	1-1/4" Aluminum X-Stream® Ring Vac® plus Filter with Auto Drain
31003X	1-1/2" Aluminum X-Stream® Ring Vac® plus Filter with Auto Drain
31004X	2" Aluminum X-Stream® Ring Vac® plus Filter with Auto Drain
32001X	1" Aluminum X-Stream® Ring Vac® plus Filter with Auto Drain & Regulator with Gauge
32002X	1-1/4" Aluminum X-Stream® Ring Vac® plus Filter with Auto Drain & Regulator with Gauge
32003X	1-1/2" Aluminum X-Stream® Ring Vac® plus Filter with Auto Drain & Regulator with Gauge
32004X	2" Aluminum X-Stream® Ring Vac® plus Filter with Auto Drain & Regulator with Gauge

A Model 30002X Heavy Duty X-Stream® Ring Vac® is used to load abrasive material into a hopper.

