

RECLASSIFYING MUFFLERS

Reclassifying Mufflers provide excellent noise reduction - as much as 35 dBA - and more so than sintered mufflers. In addition they are used to eliminate oil mist.

The exhaust air from valves and cylinders may contain oil mist that can have a negative effect on the health of employees. OSHA standard 29 CFR 1910.10 limits the cumulative exposure to oil mist to 4.32 parts per million (PPM) in any given eight hour work period.

The Reclassifying Muffler we provide uses a patented wrap design for the removable element that separates the oil from the exhausted air virtually trapping all oil in the element. Based on an intake of 50 PPM at 100 PSIG of oil, the exhausted oil mist is reduced to 0.016 PPM. A 1/4" tube can be attached to the bottom reservoir where the oil accumulates to drain it.

Each reclassifying muffler is sized to pass a certain volume of compressed air with minimal restriction to avoid any effect on the operation of cylinder or valve. For cylinders the table below makes the model number easy to choose based on the bore size and stroke of the cylinder.



RECLASSIFYING MUFFLER

Muffler needed to Exhaust in 1/2 second for a cylinder charged to 100 PSIG (6.9 BAR)												
STROKE in inches	0.5	1.0	1.5	2.0	2.5	3.0	3.5	4.0	4.5	5.0	5.5	6.0
3	0	0	0	0	0	0	0	0	0	0	0	0
6	0	0	0	0	0	0	0	0	0	1	1	2
9	0	0	0	0	0	0	0	0	1	1	2	2
12	0	0	0	0	0	0	1	1	2	2	2	3
18	0	0	0	0	0	1	2	2	2	3	4/5	4/5
24	0	0	0	0	1	2	2	3	3	4/5	4/5	C
30	0	0	0	0	1	2	2	3	4/5	C	C	C
36	0	0	0	0	2	3	3	4/5	4/5	C	C	C
42	0	0	0	1	2	3	4/5	4/5	C	C	C	C
48	0	0	0	1	2	3	4/5	C	C	C	C	C

- 0 = Model 90070
- 1 = Model 90071
- 2 = Model 90072
- 3 = Model 90073
- 4 = Model 90074
- 5 = Model 90075
- C = Contact Factory or Local Representative for assistance

Reclassifying Muffler Dimensions				
MODEL	ØA in Inches (mm)	B in Inches (mm)	C	Replacement Filter Element number
90070	1.63 (41)	3.13 (80)	1/8" NPT	9007071R
90071	1.63 (41)	3.13 (80)	1/4" NPT	9007071R
90072	2.44 (62)	4.75 (121)	3/8" NPT	9007273R
90073	2.44 (62)	4.75 (121)	1/2" NPT	9007273R
90074	3.31 (84)	6.25 (159)	3/4" NPT	9007475R
90075	3.31 (84)	6.25 (159)	1" NPT	9007475R

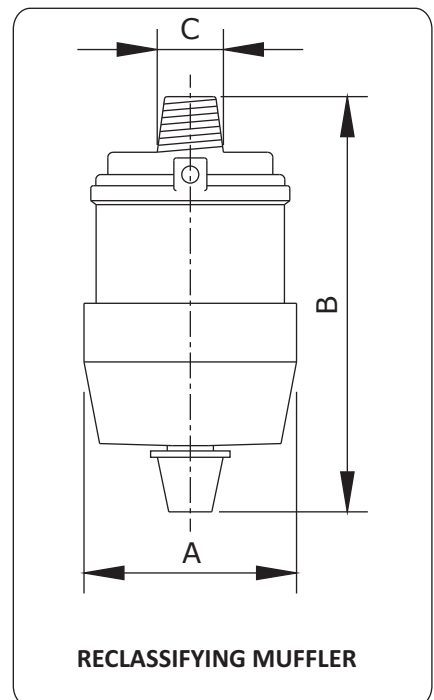

RECLASSIFYING MUFFLER