

5

4

3

2

1

D

D

C

C

B

B

A

A

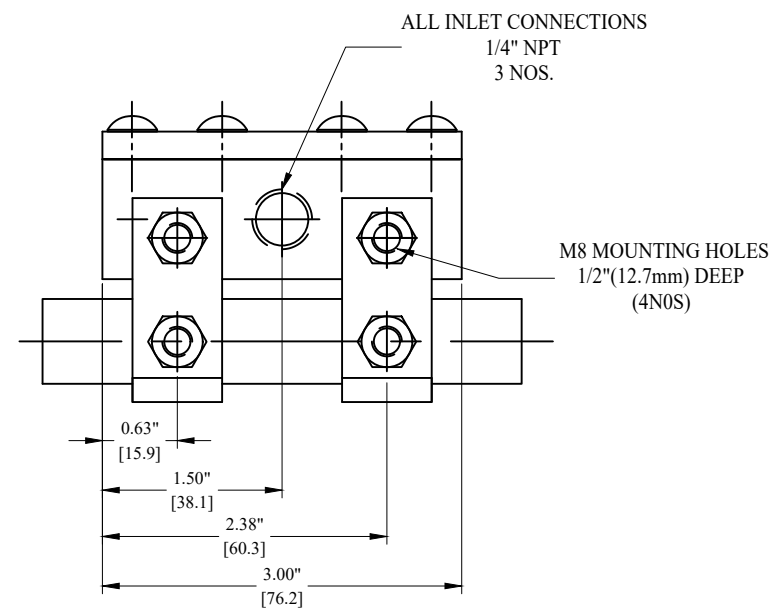
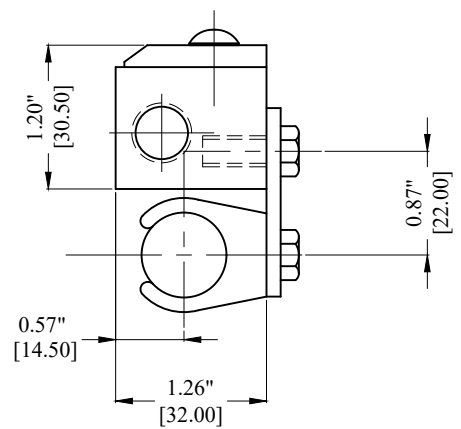
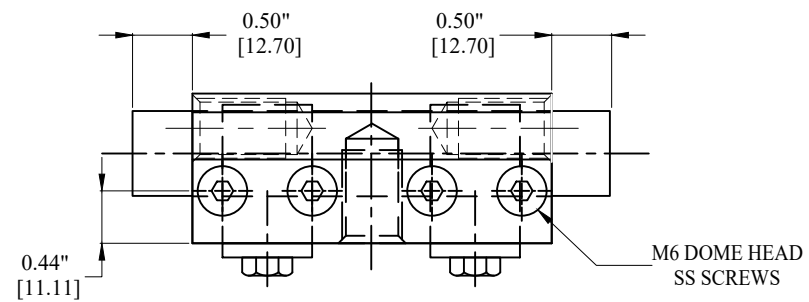

PROPRIETARY
REPRODUCTION OR DISTRIBUTION
WITHOUT WRITTEN CONSENT OF
NEXFLOW™ PRODUCTS IS PROHIBITED.



MATERIAL				
FINISH				
NEXT ASSEMBLY	USED ON	QTY PER ASSY	PART NO	
PART NO				

REQUIREMENTS—UNLESS OTHERWISE SPECIFIED			
GENERAL			
1.	DIMS ARE IN INCHES (MM)		
2.	DIMENSIONING AND TOLERANCING IN ACCORDANCE WITH ANSI Y14.5 (1982)		
3.	MACHINE FINISH 125 MICRO INCH RMS		
4.	INTERNAL RADII .015		
5.	BREAK SHARP CORNERS .005 TO .015		
LIMITS			
1.	LINEAR DIMS.		
	XX = .005		
	XX = .010		
	XX = .030		
2.	ANGLES = ± 1/2°		
3.	RUNOUT .010 TIR		

CONTRACT NUMBER	—
CLIENT	—
CONTRACTOR	—
DATE	19/11/2020
DESIGN	—
CHECKED	LES
PROJECT	G.A.
STRESS	—
MANUFACTURING	—
THERMAL	—
MATERIALS	—
MECHANISM	ELECTRICAL

SIZE	—	CAGE CODE	—	DWG NO	15003/16003	RELEASE	—	REV	—
SCALE	1:1	CAD NO	—	SHEET	1	OF	1		

NEX FLOW AIR PRODUCTS CORP.
10520 YONGE STREET, UNIT 35B-220, RICHMOND HILL, ON L4C 3C7
TEL.: (416) 410-1313 & FAX: (416) 410-1806 www.nex-flow.com

TITLE
OUTLINE DRAWING OF
3" STANDARD AIR BLADE AIR KNIFE
WITH RN IONIZER / VS IONIZER