

**FRIGID-X™ AIR  
CONDITIONING SYSTEM  
INSTALLATION &  
MAINTENANCE OF COLD  
END MUFFLER Model  
69501 and 69503**

**Guidelines:**

1. *The Cold End Muffling System comes with three fittings and muffler unit. One of the two fittings (either straight or 90 degree) screws into the muffler piece and the other end press fits onto the bottom brass cold air exit of the Panel Cooler.*

2. **PLEASE INSURE THAT YOU DO NOT PRESS FIT TO FAR UP THE BRASS TUBE OF THE PANEL COOLER AND ACCIDENTLY BLOCK THE VENT.** *The built in vent of the panel cooler allows for the hot air being displaced in the cabinet to exit. This vent must not be blocked. When pressing on the plastic fitting make sure it is secure but not too far up the brass tube where it blocks the vent.*

3. *The Cold air distribution hose normally attached to the brass cold end of the Panel Cooler is now attached to the barbed plastic fitting at the opposite and of the muffler piece.*

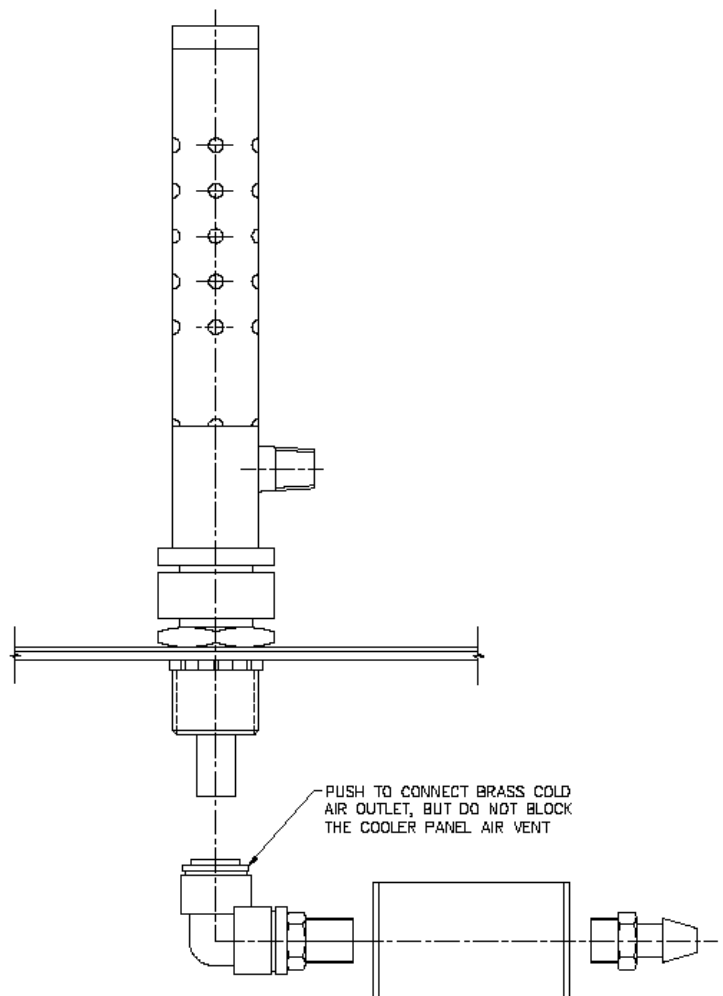

**Model 69501 using 90 degree elbow connection**

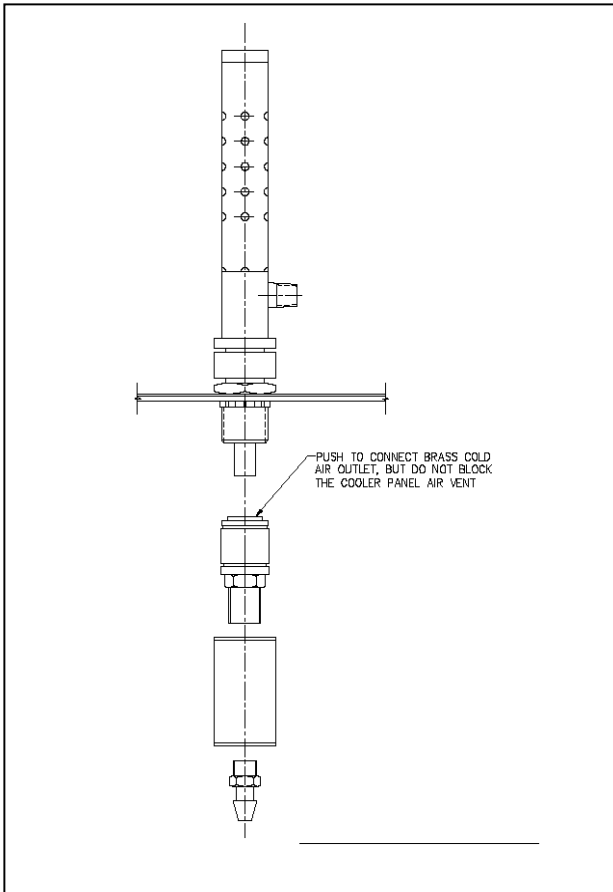

**Model 69501 using straight elbow connection**

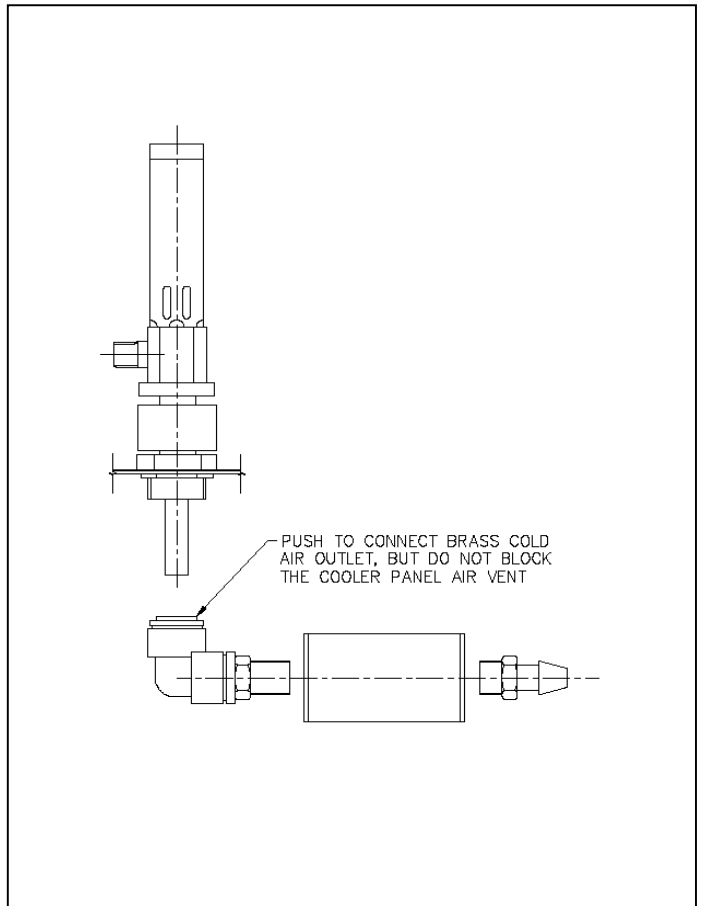

**Model 69503 using 90 degree elbow connection**

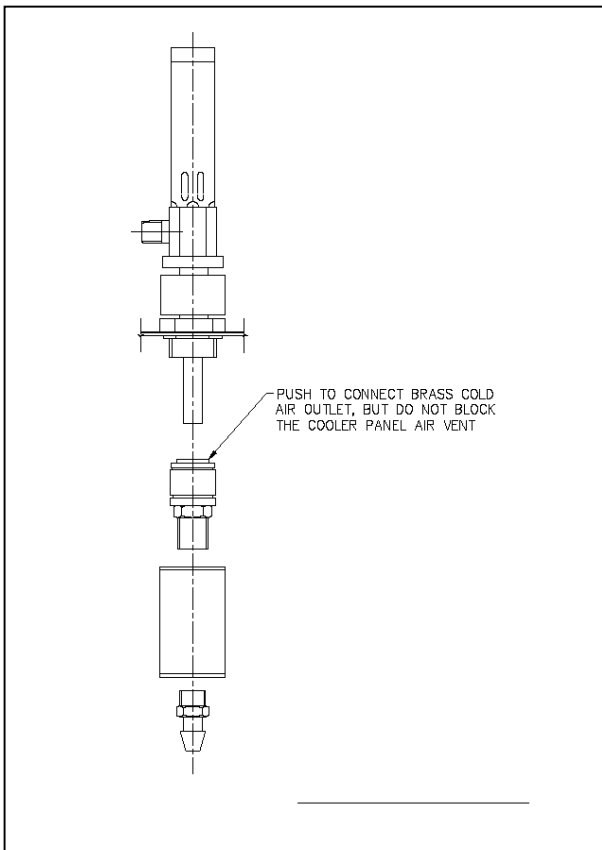

**Model 69503 using straight elbow connection**

The Nex Flow™ Cold End Mufflers for Frigid-XTM Panel Coolers reduce the dBA levels by 3 to 5 dBA depending on the capacity of the cooler.

**USA & Canada**

Tel.: (877) 797-2777  
 Fax: (877) 797-2660

**International**

Tel.: +416-410-1313  
 Fax: +416-410-1806

**Internet and Email**

[www.nexflow.com](http://www.nexflow.com)  
[sales@nexflow.com](mailto:sales@nexflow.com)

**NEX FLOW**  
 Leading Technology Into The Future